



5.16 Mechanical Systems Mechanical Systems

5.16.1 Permits

Permits (e.g. mechanical, plumbing, etc.) are required as per City of Calgary guidelines.

5.16.2 Sustainability Requirements

1. Minimum Indoor Air Quality Performance:

- a. For mechanically ventilated spaces, determine the minimum outdoor air intake flow for mechanical ventilation systems using the ventilation rate procedure from ASHRAE 62.1 (latest edition). The indoor air quality procedure defined in ASHRAE Standard 62.1 may not be used to comply with this prerequisite.
- b. Ventilation system designs must meet the minimum requirements of ASHRAE Standard 62.1 latest edition, Sections 4–7, Ventilation for Acceptable Indoor Air Quality.
- c. For mechanically ventilated spaces, monitor outdoor air intake flow as follows:
 - i. For variable air volume systems, provide a direct outdoor airflow measurement device capable of measuring the minimum outdoor air intake flow. This device must measure the minimum outdoor air intake flow with an accuracy of $\pm 2\%$ of the design minimum outdoor airflow rate, as defined by the ventilation requirements above. An alarm must indicate when the outdoor airflow value varies by 15% or more from the outdoor airflow set point.
 - ii. For constant-volume systems, balance outdoor airflow to the design minimum outdoor airflow rate defined by ASHRAE Standard 62.1, or higher. Install a current transducer on the supply fan, an airflow switch, or similar monitoring device.
- d. For spaces that are served by natural ventilation or mixed-mode ventilation systems, consult with Campus Engineering and the Office of Sustainability for the specific design standards to be applied during design.
- e. Provide documentation of the ventilation rate procedure calculations using the ASHRAE 62 User Guide 62MZCalc spreadsheet. Also, provide a written description of the equipment, methods, control sequences, set points, and the intended operational functions as well as the design criteria used and assumptions made in the analysis.

2. Thermal Comfort

- a. Design heating, ventilation and air conditioning (HVAC) systems and the building envelope to meet the requirements of ASHRAE Standard 55 (latest edition), Thermal Comfort Conditions for Human Occupancy.
- b. Wherever possible, provide individual thermal controls for 100% of individual occupant spaces. Provide group thermal controls for all shared multi-occupant spaces and for any individual spaces without individual controls.



- c. Provide plots or calculations verifying that design parameters meet ASHRAE Standard 55 for 80% acceptability (e.g. psychometric chart, PMV or PPD calculations; ASHRAE Thermal Comfort Tool results).

3. Indoor Water Use

- a. Low flow fixtures and appliances must be utilized.
 - i. Standard water closets shall not exceed 4.8 Litres per flush (LPF).
 - ii. Dual-flush water closets shall not exceed 6/4.2 LPF.
 - iii. Urinals shall not exceed 0.5 LPF.
 - iv. Public lavatory faucets shall not exceed 1.9 Litres per minute (LPM)
 - v. Public metering self-closing faucet shall not exceed 1.0 Litre per metering cycle
 - vi. Residential bathroom lavatory faucet shall not exceed 5.7 LPM
 - vii. Kitchen faucets shall not exceed 8.3 LPM
 - viii. Showerheads shall not exceed 6.8 LPM
 - ix. Residential dishwashers must be ENERGY STAR
- b. No once-through cooling with potable water is permitted for any equipment or appliances that reject heat.
- c. All cooling towers and evaporative condensers must be equipped with:
 - i. Makeup/blowdown water meters,
 - ii. Conductivity controllers and overflow alarms, and
 - iii. Efficient drift eliminators that reduce drift to maximum of 0.002% of recirculated water volume for counter-flow towers and 0.005% of recirculated water flow for cross-flow towers.

4. Acoustics

- a. Achieve maximum background noise levels from heating, ventilating, and air conditioning (HVAC) systems per ASHRAE Handbook, HVAC Applications, Chapter 48, Table 1.

5.16.3 Codes, Regulations and Standards

Comply with all applicable codes, regulations and standards. This list is not meant to restrict the use of additional codes, regulations or standards.

- 1. Canadian Standards Associations (CSA) Standards:
 - a. *CSA B52: Mechanical Refrigeration Code.*
 - b. *CAN/CSA B149.1: Natural Gas and Propane Code.*

- c. *CSA Z316.5*: Fume Hoods and Associated Exhaust Systems.
 - d. *CSA B51*: Boiler, Pressure Vessel and Pressure Piping Code.
 - e. *CSA B242*: Groove and Shoulder Type Mechanical Couplings.
2. Alberta Building Code
 3. National Plumbing Code of Canada
 4. Alberta Fire Code
 5. The Boiler and Pressure Vessel Act (Alberta)
 6. The Occupational Health and Safety Act and Regulations (Alberta)
 7. National Fire Protection Association (NFPA) Standards:
 - a. *NFPA 10*: Portable Fire Extinguishers
 - b. *NFPA 13*: Installation of Sprinkler Systems
 - c. *NFPA 14*: Installation of Standpipe and Hose Systems
 - d. *NFPA 20*: Installation of Stationary Fire Pumps
 - e. *NFPA 90A*: Installation of Air Conditioning and Ventilation Systems
 - f. *NFPA 96*: Ventilation Control and Fire Protection of Commercial Cooking Equipment
 8. ASHRAE Handbooks
 9. ASPE Handbooks
 10. ASHRAE Standards:
 - a. *ANSI/ASHRAE 52.2*: Method of Testing General Ventilation Air-Cleaning Devices for Removal Efficiency by Particle
 - b. *ANSIASHRAE 55*: Thermal Environmental Conditions for Human Occupancy
 - c. *ANSI/ASHRAE 62.1*: Ventilation for Acceptable Indoor Air Quality
 - d. *ANSI/ASHRAE/IESNA 90.1*: Energy Standard for Buildings Except Low-Rise Residential Buildings
 - e. *ANSI/ASHRAE 111*: Testing, Adjusting, and Balancing of Building HVAC
 - f. *ANSI/ASHRAE/USGBC/IES Standard 189.1*: Standard for the Design of High-Performance Green Buildings Except Low-Rise Residential Buildings
 11. SMACNA Standards
 - a. SMACNA 1072: IAQ Guidelines for Occupied Buildings Under Construction

12. Industrial Ventilation: A manual of Recommended Practice, American Conference of Governmental Industrial Hygienists
13. Daylighting Guide for Canadian Commercial Buildings (August 2002), Public Works and Government Services Canada
14. Health Canada, Indoor Air Quality in Office Building: A Technical Guide.
15. American National Standards Institute
 - a. ANSI Z358.1, Emergency Eye Wash and Shower Equipment
16. ASME Boiler Pressure Vessel Code

5.16.4 Design Criteria

1. General

- a. Design all new buildings to provide an annual energy cost reduction in the proposed building of 38% when compared to a baseline defined according to Appendix G of ANSI/ASHRAE/IESNA Standard 90.1.
- b. Design all major retrofits to provide an annual energy cost reduction in the proposed building of 36% when compared to a baseline defined according to Appendix G of ANSI/ASHRAE/IESNA Standard 90.1.
- c. The proposed design will include all energy consumption and costs within and associate with the building project. Unregulated loads are to be modelled accurately to reflect the actual expected energy consumption of the building.
- d. The University of Calgary will establish an emissions performance target no later than the schematic design phase. The target will be established as tonnes CO₂ equivalent per square meter-year (tonnes CO₂e/m²·yr).
- e. Ensure sufficient space and access is provided around mechanical equipment for safety, ease of maintenance and future component replacement.
- f. Provide access to mechanical shafts for maintenance.
- g. Arrange equipment and incorporate components into mechanical systems to facilitate balancing and commissioning.
- h. When evaluating system alternatives, base decisions on life cycle cost analysis.
- i. Incorporate cost effective energy conservation measures that do not comprise building performance or occupant comfort.
- j. All grooved couplings, and fittings, valves and specialties shall be the products of a single manufacturer. Grooving tools shall be of the same manufacturer as the grooved components.
 - i. All castings used for coupling housings, fittings, valve bodies, etc., shall be date stamped for quality assurance and traceability.

2. Outdoor Design Criteria

- a. Base design of heating and cooling systems on outdoor ambient temperatures given in the Alberta Building Code.
 - i. Cooling - July, 2.5% value
 - ii. Heating - January, 1% value

3. Indoor Design Criteria

- a. Indoor design requirements are to meet minimum requirements of ASHRAE 55-2013

4. Indoor Environmental Quality

a. Air Quality

- i. The outdoor air ventilation quantities specified by ASHRAE Standard 62.1 are the minimum acceptable. Instrumentation and controls shall be provided to ensure outdoor air intake rates are maintained during occupied hours.
- ii. Provide documentation summarizing the design criteria used and assumptions made as per the requirements of ASHRAE 62.1. It is suggested that the reporting format follow the templates provided in Appendix H of the standard.
- iii. Air filtration shall be provided in every air handling system.
- iv. Air handling units to be easily accessible through access doors, easy to clean and tightly sealed. Condensate pans inside air handling units should be adequately sloped and piped to floor drains.
- v. Floor drains should be trap primed where required to ensure integrity of trap seal.
- vi. Intake louver locations should be away from exhaust air discharge areas, parking areas, waste stacks, loading docks and other nearby sources of contamination.
- vii. Carbon dioxide and carbon monoxide levels to meet ASHRAE 62 guidelines.
- viii. Project contract documents shall include for indoor air quality testing, after construction ends and prior to occupancy, for Formaldehyde, Particulates PM10, Total Volatile Organic Compounds (TVOC) and Carbon Monoxide to LEED Canada for New Construction requirements.
- ix. The use of Victaulic joints shall be considered for applicable piping systems to reduce the amount of required weld gas and emissions and improve air quality during the construction phase of the project. Pre-approval from Campus Engineering is required prior to Victaulic joints being utilized on heating systems.

b. Thermal Comfort

- i. Design heating, ventilation and air conditioning (HVAC) systems and the building envelope to meet the requirements of ASHRAE Standard 55, Thermal Comfort Conditions for Human Occupancy (with errata but without addenda).

- ii. Demonstrate design compliance in accordance with Section 6.1.1 of the standard.
- c. Control of Building Systems
 - i. Optimize the amount of fresh air provided to building spaces through feedback from occupancy and carbon dioxide monitors to HVAC systems where feasible.
 - ii. Provide temperature control for each similar group of occupied spaces to manage comfort variation according to orientation and other factors as well as occupant preferences.
 - iii. Provide temperature and humidity monitoring and control systems in special use buildings.
- d. Acoustic Quality
 - i. Isolate mechanical equipment by appropriate isolation and enclosing equipment inside rooms with sound absorbing walls, floors and ceilings.
 - ii. Use external insulation, sound attenuators or internal acoustic insulation for sound control on ducts.
 - iii. Use water hammer arrestors and pipe sleeves through wall penetrations where required.
 - iv. Refer to section 1.15, Noise and Vibration Control.
- 5. Maintenance Provisions
 - a. Access Doors
 - i. Provide access doors to all concealed mechanical equipment for operating, inspecting, adjusting and servicing.
 - ii. Access doors are not required in lay-in tile ceilings. In this case, use unobstructed identification locators at all applicable tile locations.
 - iii. Minimum access door sizes to be:
 - 600 x 600 mm (24"x24") for body entry
 - 300 x 300 mm (12"x12") for hand entry
 - iv. Access doors to have rounded, safety corners, concealed hinges, screwdriver latch, anchor straps and able to open 180 degrees.
 - v. Location of access door to be shown on the drawings.
 - b. Fire Dampers
 - i. Minimum duct size for fire dampers to be 150 mm (6").
 - c. Mechanical Shafts



- i. Provide access doors into mechanical shafts at each floor level.
 - ii. Provide grated flooring in mechanical shafts at each floor level.
 - iii. Ensure there is adequate space to access fire dampers and isolation valves.
- d. Variable Frequency Drives
- i. Variable frequency drive control key pads to be mounted at operator level.
 - ii. Variable Frequency Drive control key pads, drive bypass switches and local disconnects shall be mounted at operator level without the use of platforms and/or ladders.

5.16.5 Heating

1. General

- a. Piping shall conform to Alberta Boilers and Pressure Vessels Regulations and Safety Codes Act and ANSI B31.1.
- b. Refer to Appendix A for approved alternate list.
- c. Refer to Appendix C for pipe and fitting materials list.

2. Connection to Campus Utility Infrastructure

- a. Refer to Section 1.11 for high temperature hot water connection to Service Tunnel services.
- b. Provide two tube in shell heat exchangers where the high temperature hot water is in the tubes and lower temperature heating water in the shell. Each heat exchanger shall be sized for 75% of the peak simultaneous heating load.
- c. Construction of shell in tube heat exchangers to be:
 - i. Shell: carbon steel 1035 kPa (150 psi) working pressure. 150ASA raised face flanged connection. Tappings for relief valve drain only. Shell to be carbon steel SA-53B. Required thickness to be calculated in accordance of ASME code.
 - ii. Head: Flanged fabricated heads to SA-53B. Weld joints to be spot radiograph. Tapped connections for vent and drain. Provide lift-in lugs for ease of removal on units over 350 mm (14") diameter.
 - iii. Tube: To be 316 stainless steel, 20mm ($\frac{3}{4}$ ") O.D., 18 Bwg Avg. Tube sheet to have two tapped holes in face for pulling eyes on units over 350 mm (14") diameter.
 - iv. Tube sheets: Carbon steel, Grade SA-516-70 – tube sheet is “clamped” between the head and the shell flanges. Both shell and head flanges are assembled with high tensile bolting. Tube sides may be vented and drained through tube side nozzles.
 - v. Minimum 0.0005 fouling factor.
 - vi. Mounting supports: steel or cast iron saddles.



- vii. Gaskets: Head and shell gaskets shall be spiral wound “Flexitalic” style.
 - viii. Baffles: Carbon steel.
 - ix. Trim: ASME rated #174 relief valve. Connect to top of shell independent of nozzle.
 - x. Prime coat exterior.
- d. Design working pressure of 1035 kPa (150 psi) on the shell side and 2760 kPa (400 psi) on the tube side.
 - e. Design temperature of 104°C (220°F) on the shell side and 204°C (400°F) on the tube side.
 - f. The high temperature hot water temperature difference between supply and return to be 66°C (150 °F).
3. Heating Distribution
- a. All heating piping to be designed with layout that avoids piping installed over electrical panels, server rooms or other electrical equipment that would sustain damage in the event of piping leaks.
 - b. Preference should be given to the two-pipe reverse return system for heating water piping. Two-pipe direct return system may be used only if the design properly guards against flow imbalance to terminal units, and it is a small part of a reverse return system.
 - c. Consider primary-secondary pumping only where it will reduce power consumption and provides better control.
 - d. Provide duty / standby pumps on all main heating distribution pumps.
 - e. Mount all pumps greater than three (3) horsepower at floor level. No racking or stacking of pumps is acceptable. Base mounted pumps to be installed on housekeeping pads.
 - f. Provide means of isolation, balancing and flow measuring devices at major pieces of equipment and major circuits.
 - g. Use separate steam and condensate piping systems. Single pipe steam systems shall not be used.
 - h. Provide isolation valves on:
 - i. supply and return mains
 - ii. risers
 - iii. branch lines from mains
 - iv. equipment connections
 - i. Use variable speed pumps to maintain required system pressures when variable flow distribution systems are provided.



- j. Provide unions on all low-pressure hydronic system safety valves, located on the atmospheric discharge lines at the closest point to the safety valve for the purposes of removing the safety valve easily during maintenance purposes.
- k. Provide side stream filters that are common to both pumps. Ensure filters are properly sized and oriented.
- l. Provide corrosion coupons
- m. Heating two-way control valves should always fail open.
- n. Provide means of isolation immediately upstream AAV (Auto Air Vents).

4. Heating Terminal Units

- a. Ensure heating terminal units are easily accessible for inspection, cleaning and disinfection.
- b. All terminal box reheat coils shall be provided with upstream and downstream removable access hatches that allow full inspection of both the upstream and downstream re-heat coil faces, and in every application. This shall also include any application where there is a cooling coil for terminal boxes and in each section of the terminal unit where both heating and cooling are provided , each section shall allow full access to each coil face
- c. Valve each terminal unit at the supply and return connections. Balancing valve must be provided at each terminal unit. Refer to figure below for typical heating equipment piping schematic.

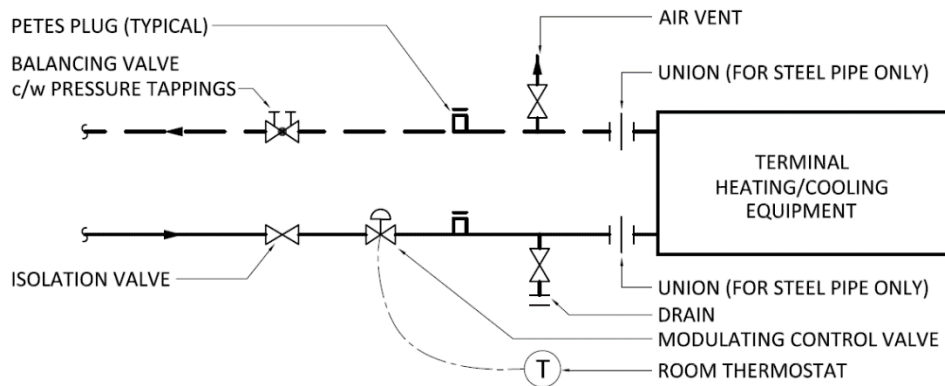

- d. Reheat coils, tied into any main, and shall have flexible rated connections to compensate for terminal box deflection on the equipment side

5. Heating Systems

- a. Select systems based on maintainability, controllability and life cycle costs.
- b. Provide individual thermostatic zoning for each instructional space.



- c. Design perimeter heating and ventilation to prevent cold interior surface temperatures on glazing.
 - d. Provide cleaning, degreasing and chemical treatment on hot water heating systems.
 - e. Vestibule cabinet heaters to run “wild” on the HW side and fan to be cycled on/off on a call for heating from the temperature sensor. Sensors to be alarmed and monitored by BMS. Line voltage thermostats are not permitted.
6. Expansion Compensation
- a. Show all required expansion joints, guides and anchor points on heating drawings.
 - b. For water systems, Victaulic flexible couplings may be used to accommodate thermal growth, contraction, and for the elimination of expansion loops. (In accordance with the manufacturer’s written recommendations.) Where loops are required, use flexible couplings on the loop.

5.16.6 Glycol

1. Utilize only propylene glycol/water solution (phosphate-based) suitable for a temperature range at -36°C (-33°F) to 104°C (220°F). Solution to be suitable for heating or cooling complete with appropriate corrosion inhibitors. Solutions must be factory premixed.
2. Provide relief valves on pressure tanks, low-pressure side of reducing valves, and expansion tanks.
3. Drain relief valve to glycol collection tanks. Do not waste glycol to floor drains.
4. Provide one pump for each glycol fill tank with local automatic injection capability.
5. Provide one glycol-charging tank for each glycol system.
6. Provide duty / standby pumps on all main glycol distribution pumps.
7. Mount all pumps greater than 2.2 kW (three hp) at floor level.
8. Provide corrosion coupons
9. Glycol two-way control valves should always fail open.

5.16.7 Cooling

1. General
 - a. Use outdoor air for free cooling when ambient conditions permit. Base cooling design on outdoor ambient temperatures given in the Alberta Building Code.
 - b. Refer to Appendix A for approved alternate list.
 - c. Refer to Appendix C for pipe and fitting materials list.
2. Connection to Campus Utility Infrastructure
 - a. Refer to Section 1.11 for chilled water connection to Service Tunnel services.



- b. The chilled water is never to be consumed at any point and is never to come in contact with any other fluid in the building. It is solely to be used as a chilling medium within a heat exchanger or a coil.
- c. Circulation of chilled water within a building to be accomplished by secondary pumping to overcome the friction head of building circuits and to hold the supply and return temperature differential to 15°F (minimum of 10°F differential).
- d. Provide two-way control valves at all chilled water connections to tunnel services.

3. Cooling Distribution

- a. Provide two-way control valves at all chilled water connections air handling unit-cooling coils.
- b. All chilled water piping to be designed with layout that avoids piping installed over electrical panels, server rooms or other electrical equipment that would sustain damage in the event of piping leaks.
- c. Provide duty / standby pumps on all main chilled water distribution pumps (each sized at 100% of the load).
- d. Preference should be given to the two-pipe reverse return system for chilled water piping. Two-pipe direct return system may be used only if the design properly guards against flow imbalance to terminal units, and it is a small part of a reverse return system.
- e. Provide means of isolation, balancing and flow measuring devices at major pieces of equipment and major circuits.
- f. Provide isolation valves on:
 - i. supply and return mains
 - ii. risers
 - iii. branch lines from mains
 - iv. equipment connections
- g. Use variable speed pumps where justified by cost or control to maintain required system pressures when variable flow distribution systems are provided.
- h. Mount all pumps greater than three 2.2 kW (three hp) at floor level.
- i. Consult with University of Calgary Campus Engineering if duplex pumps are required for main building cooling distribution.
- j. Provide side stream filters that are common to both pumps. Ensure filters are properly sized and oriented.
- k. Provide corrosion coupons

4. Cooling Systems

- a. Provide two way control valves at all chilled water connections cooling coils



- b. Select systems based on maintainability, controllability and life cycle costs.
- c. Provide individual thermostatic zoning for each instructional space.
- d. Refer to figure below for typical cooling equipment piping schematic.
- e. Regarding coil detail below, provide isolation downstream balancing valve, double duty balancing/shutoff should not be used as a purpose of isolation.

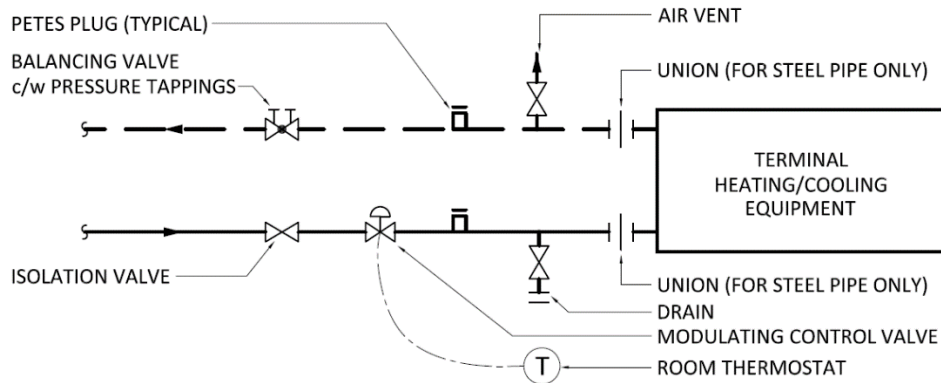

5.16.8 Cleaning and Degreasing

NOTE: Oil free compressors shall comply with ISO 8573.

1. General

- a. Provide for cleaning and degreasing of:
 - i. Glycol systems
 - ii. Heating systems
 - iii. Chilled systems
 - iv. Cooling tower piping (condenser) systems
- b. Provide for flushing and disinfection of:
 - i. Domestic water systems
 - ii. Humidification systems.
- c. Design schematics to have provisions for plate exchange bypass and drainage for heat exchangers, cooling towers, etc.

5.16.9 Low Pressure Steam

1. General

- a. Humidification shall be considered on project-by-project basis. Consult with Campus Engineering.



- b. Piping shall conform to Alberta Boilers and Pressure Vessels Regulations and Safety Codes Act and ANSI B31.1.
- c. Refer to Appendix A for approved alternate list.
- d. Refer to Appendix C for pipe and fitting materials list.

2. Connection to Campus Utility Infrastructure

- a. Refer to Section 1.11 for high temperature hot water connection to Service Tunnel services.
- b. Provide tube in shell heat exchangers where the high temperature hot water is in the tubes and low-pressure steam in the shell.
- c. Construction of shell in tube heat exchangers to be:
 - i. Shell: Carbon Steel 1035 kPa (150psi) working pressure. 105ASA raised face flanged connection. Tappings for relief valve drain only. Shell to be carbon steel SA-53B. Required thickness to be calculated in accordance of ASME code.
 - ii. Head: Flanged fabricated heads to SA-53B. Weld joints to be spot radiograph. Tapped connections for vent and drain. Provide lift-in lugs for ease of removal on units over 350 mm diameter.
 - iii. Tube: To be 316 stainless steel, 20mm (¾") O.D., 18 Bwg Avg. Tube sheet to have two tapped holes in face for pulling eyes on units over 350mm (14") diameter.
 - iv. Tube sheets: Carbon steel, Grade SA-516-70 – tube sheet is “clamped” between the head and the shell flanges. Both shell and hand flanges are assembled with high tensile bolting. Tube sides may be vented and drained through tube side nozzles.
 - v. Minimum 0.0005 fouling factor.
 - vi. Mounting supports: steel or cast iron saddles.
 - vii. Gaskets: Head and shell gaskets shall be spiral wound “Flexitalic” style.
 - viii. Baffles: Carbon steel.
 - ix. Trim: ASME rated #174 relief valve. Connect to top of shell independent of nozzle.
 - x. Prime coat exterior.
 - xi. Design working pressure of 1035 kPa (150 psig) on the shell side and 2760 kPa (400 psig) on the tube side.
 - xii. Design temperature of 190.5°C (375°F) on the shell side and 204°C (400°F) on the tube side.
 - xiii. The high temperature hot water temperature difference between supply and return to be 66°C (150 °F).

3. Steam Throttling Calorimeter fittings serving process equipment (Sterilizers)



- a. For the main steam piping serving any sterilizer, placed at the closest point in the piping upstream of the process equipment a weld in place horizontally fixed connection to allow a Steam Throttling Calorimeter connection.
- b. Place in the upstream location of item a) above, a steam pressure gage pigtail fitting (comes with isolation valve, gage and pigtail to obtain steam line pressure. Fitting to be placed just upstream of the Throttling Calorimeter fitting used in a),

5.16.10 Grooved Mechanical Pipe and Fittings

1. General:

- a. Any use of grooved piping systems, with the exception of sprinkler systems, shall be pre-approved by Campus Engineering
- b. 50 mm [NPS 2] and Smaller: Pipe shall be Schedule 10S, Type 304/304L, stainless steel conforming to ASTM A312, with plain ends for use with the Vic-Press Piping System.
 - i. Fittings shall be precision, cold drawn, stainless steel with elastomer O-ring seals, suitable for working pressure to 500-psig (3450-kPa).
- c. 50 mm [NPS 2] and Larger: For use with black steel pipe as specified.
 - i. Fittings: Ductile iron conforming with ASTM A536, Grade 65-45-12; wrought steel to ASTM A234, Grade WPB; or factory-fabricated from carbon steel pipe conforming to ASTM A53; with grooved ends conforming to CSA B242. Standard of Acceptance: Victaulic Company.
 - ii. Victaulic Standard Mechanical Couplings: Manufactured in two segments of cast ductile iron, conforming to ASTM A-536, Grade 65-45-12. Gaskets shall be pressure-responsive synthetic rubber, grade to suit the intended service, conforming to ASTM D-2000. Mechanical Coupling bolts shall be zinc plated (ASTM B-633) heat treated carbon steel track head conforming to ASTM A-449 and ASTM A-183. Couplings shall comply with ASTM F1476 – Standard Specification for Performance of Gasketed Mechanical Couplings for Use in Piping Applications.
 - iii. Rigid Type: Coupling housings with offsetting, angle-pattern bolt pads shall be used to provide system rigidity and support and hanging in accordance with ANSI B31.1, B31.9. Victaulic Style 107H/107N (Quick-Vic™), Installation ready rigid coupling for direct stab installation without field disassembly. Gasket shall be Grade “EHP” EPDM designed for operating temperatures from -30 deg F (-34 deg C) to +250 deg F (+120 deg C).
 - iv. Flexible Type: Use in locations where vibration attenuation and stress relief are required. Flexible couplings may be used in lieu of flexible connectors at equipment connections. Three couplings, for each connector, shall be placed in close proximity to the vibration source. Victaulic Style 177 (Quick-Vic™) or Victaulic Style 77 flexible couplings.
 - v. Victaulic AGS Mechanical Couplings, 14 inch (DN350) through 60 inch (DN1500): Couplings shall consist of two ASTM A-536 ductile iron housing segments with lead-in chamfer on housing key, a wide-width elastomer pressure responsive gasket, and

zinc electroplated carbon steel track head bolts and nuts conforming to ASTM A-449.
Victaulic Style W07 AGS Rigid Coupling and Style W77 AGS Flexible Coupling

2. Valves:

- a. Ball Valves: ASTM B30 forged brass body, chrome-plated brass ball and stem, PTFE seats, zinc-plated carbon steel handle, with austenitic stainless steel ends for use with Vic-Press™ couplings and fittings. Rated for services to 300 psi (2065 kPa). Victaulic Series P589.
- b. Butterfly Valves: 50mm [NPS 2] through 300mm [NPS12] Sizes: 300 psi CWP (2065 kPa) suitable for bidirectional and dead-end service at full rated pressure. Body shall be grooved end black enamel coated ductile iron conforming to ASTM A536. Disc shall be [electroless nickel-plated ductile iron] [stainless steel] [aluminum bronze] with blowout proof 416 stainless steel stem. Disc shall be offset from the stem centerline to allow full 360 degree seating. Seat shall be pressure responsive [EPDM] [Lubricated Nitrile] [Fluoroelastomer]. Valve shall be complete with ISO flange for actuation mounting. Valve operators shall be lever handle or gear operator. Victaulic Vic®-300 MasterSeal™
- c. Butterfly Valves: 350mm [NPS 14] through 600mm [NPS 24] Sizes: 300 psi (2065 kPa), AGS grooved ends, polyphenylene sulfide (PPS) coated ductile iron body (ASTM A-536, Grade 65-45-12), PPS coated ductile iron disc (ASTM A-536), and two piece 17-4 PH S/S stem design. Seat and seal material to suit intended service. Reinforced PTFE bearings and gear operator. Bubble tight, dead-end, or bi-directional service. With memory stop for throttling, metering or balancing service. Victaulic Vic®-300 AGS.
- d. Check Valves: 50mm [NPS 2] through 300mm [NPS 12] Sizes: Coated ductile iron body, ASTM A-536, Grade 65-45-12, stainless steel with elastomer seal or elastomer encapsulated ductile iron disc, suitable for intended service, stainless steel spring and shaft, for vertical or horizontal installation, 300 psi (2065 kPa). Victaulic Series 716 and 779.
- e. Check Valves: 350mm [NPS 14] through 600mm [NPS 24] Sizes: 230 psi (1585 kPa), AGS grooved ends, spring-assisted dual disc check valve. ASTM A-536, Grade 65-45-12 coated ductile iron body, EPDM seat bonded to the valve body, 304 stainless steel disc, and 300 series stainless steel spring and shaft. Victaulic Series W715.
- f. Circuit Balancing Valves:
 - i. 50mm [NPS 2] and Smaller: 300 psi (2065 kPa), y-pattern, globe type with soldered or threaded ends, non-ferrous Ametal® brass copper alloy body, EPDM O-ring seals. 4-turn digital readout hand wheel for balancing, hidden memory feature with locking tamper-proof setting, and connections for portable differential meter. Victaulic / TA Hydronic Series 786 or 787 STAD.
 - ii. Coil-Hook-up Connections: Victaulic Koil-Kits Series 799 or 79V may be used at coil connections. The kit shall include a Series 786/787/78K circuit-balancing valve, Series 78Y Strainer-Ball, Series 78U Union-Port fitting, with Series 78T ball valve and required coil hoses. A Style 793 and/or 794 differential pressure controller shall be provided as required. The valve manufacturer that shall



remain with the building owner after commissioning shall provide a meter.

- iii. 65mm [NPS 2-1/2] and Larger: 300 psi (2065 kPa), y-pattern, globe type with flanged or grooved ends, ASTM A536 ductile iron body, all other metal parts of Ametal® brass copper alloy, EPDM O-ring seals. 8, 12 or 16-turn digital readout hand wheel for balancing, hidden memory feature with locking tamper- proof setting, and connections for portable differential meter. Victaulic / TA Hydronic Series 788 or 789 STAG.
3. Grooved joints shall be installed in accordance with the manufacturer's latest published installation instructions. Grooved ends shall be clean and free from indentations, projections, and roll marks. Gaskets shall be molded and produced by the coupling manufacturer, and shall be verified as suitable for the intended service. A factory- trained field representative (direct employee) of the mechanical joint manufacture shall provide on-site training for contractor's field personnel in the proper use of grooving tools and installation of grooved piping products. The factory-trained representative shall periodically review the product installation and ensure best practices are being followed. Contractor shall remove and replace any improperly installed products. A distributor's representative is not considered qualified to conduct the training.

5.16.11 Air Handling Systems

1. General

- a. Any unused ductwork during demolition should be removed back to the source and capped. Ductwork should never be abandoned in place, regardless of circumstances.
- b. Design air-handling systems to maintain environmental conditions in accordance with the minimum requirements of ASHRAE 62 latest issue.
- c. Zone air systems in accordance with space function and occupied hours. Consult with the University of Calgary regarding other special areas that may require separate air units. Design air handling systems to provide free cooling, utilizing outdoor air when ambient conditions permit.
- d. Clean all new and existing ductwork and air handling equipment prior to occupancy.
- e. Do not use mechanical rooms as air plenums.
- f. For 100% outdoor air units, use heat recovery devices and reduce airflows during unoccupied hours.
- g. AHUs should be sized to accommodate an extra 15% of airflow capacity.

2. Air Handling Equipment

- a. Provide indoor air handling units unless otherwise approved by Campus Engineering.
- b. Indoors units to rest on raised concrete housekeeping pads.
- c. Outdoor units shall have enclosed heated service corridors. Units to rest on concrete roof curb. Roof hatch access is not acceptable.



d. Fan array systems are preferable and when utilized must comply with the following specifications:

- i. The fan array shall consist of multiple housed fans or “cells”, spaced in the airway tunnel cross section to provide a uniform airflow and velocity profile across the entire air tunnel cross section and components contained therein.
 - ii. Fan shall be aluminum airfoil, Class III, direct drive arrangement and shall be individually housed. Fans shall be certified by AMCA for performance. Fan shall be housed in a “cell”. Class I and Class II fans are not acceptable.
 - iii. Fan housing or “cell” shall be constructed of aluminum with perforated inner liner, melamine insulation, with either solid or perforated outer panels as required by application.
 - iv. Fan/motor assembly shall be mounted within the housing on an adjustable slide rail base. Fan/motor assembly must be capable of either horizontal or vertical application.
 - v. Each fan/motor assembly shall be dynamically balanced to meet AMCA standard 204-96, for fan application class BV-5, to meet or exceed a rotational imbalance Grade G.55, producing a maximum rotational imbalance of .022” per second peak, filter in (.55mm per second peak, filter in). “Filter in” measurement indicates that the specified balance grade must be achieved at the submitted design operating speed for the fan(s). Fan and motor assemblies submitted for approval incorporating larger than 215T frame shall be balanced in three orthogonal planes of demonstrate compliance with the G.55 requirement with a maximum rotational imbalance of .022” per second peak filter in (.55 mm per second peak, filter in).
 - vi. Fan and motor assemblies shall be designed for application in multiple fan arrays.
- e. Provide plenums with hinged, sealed access doors to access all components. Provide windows and lighting for inspection of each chamber.

3. Heat Recovery

- a. Heat recovery equipment shall operate at a minimum of 70 percent efficiency.
- b. Heat recovery equipment should be connected to the building automation system.
- c. Pre-filters shall be provided in all heat recovery equipment.
- d. A ducted bypass c/w isolation damper should be added around round-around-coils to facilitate maintenance

4. Filtration

- a. Filter sections shall be designed at 2.5 m/s (500 fpm) maximum face velocity.
- b. For 100% fresh air systems, high outdoor air systems or return air heat recovery systems typically with heat wheels, a summer position and winter position pre-filters are required before and after the initial preheat coil. Final filter are to be located further downstream. The return air should also be filtered to protect the heat wheel.



- c. Provide the following types of filters at locations indicated:
- i. Pre-filter ahead of preheat coil to be Merv 5 – 4” heavy-duty red fiberglass pads.
 - ii. Pre-filter behind preheat coil to be Merv 7 – High capacity pleats complete with 15 pleats/lineal foot.
 - iii. Pre-filter in return air to be Merv 7 – High capacity pleats complete with 15 pleats/lineal foot.
 - iv. Final filter to be Merv 13, 85% ASHRAE efficiency – 6mm (¼”) thick fiberglass wool pocket filters.
- d. Standard sizes for filters used at the University of Calgary are:
- i. Prefilters: Merv 5 – 4” heavy-duty red fiberglass pads standard sizes shall be 300x600x100 mm (12”x24”x4”) and 600x600x100 (24”x24”x4”).
 - ii. Final filters: Merv 13, 85% ASHRAE efficiency – 6 mm (¼”) thick fiberglass wool pocket filters standard sizes shall be:
 - 600x600x750 mm (24”x24”x30”) – 8 pocket
 - 300x600x750 mm (12”x24”x30”) – 4 pocket
 - 600x600x550 mm (24”x24”x22”) – 8 pocket
 - 300x600x550 mm (12”x24”x22”) – 4 pocket
 - 600x600x300 mm (24”x24”x12”) – 12 pocket
 - 300x600x300 mm (12”x24”x12”) – 6 pocket
 - e. Filters are to be held in a common universal holding frame for upstream service with universal clip hardware to secure filters in place. Side access application should be avoided except for systems of limited access or filter banks less than 16.5 m (5 feet) high.
 - f. Common holding frame would be a minimum of 18 GA galvanized steel and the separate pre-filter frame should be 18 GA galvanized steel with a welded wire support grid with mesh of not greater than 2580 mm² (4 in²). Expanded metal support grids are not acceptable.
 - g. Common holding frames on filter banks over 5 feet in height must have additional support structure in the form of 18 GA galvanized flat stock 150 mm (6”) wide sandwiched between every second vertical row of frames for the full height of the filter bank to prevent collapse.
 - h. Electrostatic filters will NOT be accepted.
5. Humidification
- a. For steam generation, refer to Low Pressure Steam for Humidification Section 1.6.
 - b. Steam shall be injected into the supply air stream with a steam distribution manifold.
 - c. Make-up water for humidification shall be supplied by the feed water system located in

the service tunnel.

6. Zoning

- a. Building functions which are subject to different operating schedules shall be served by separate systems. For example, areas which require twenty-four hour a day operation, such as libraries, laboratories, computer rooms, should be served from a separate system from that of offices or classrooms. Consult with the Owner for usage schedules for each project.
- b. Air handling systems shall not be used to offset building heat loss. Building temperature must be able to be maintained without air handling system operation.

7. Distribution

- a. Ductwork shall be fabricated from galvanized steel or stainless steel depending on application.
- b. Provide bull-head tee connection for all ceiling diffusers.
- c. Flex duct may be used for low-pressure ductwork. Flex duct runs shall not exceed 900mm (36") and shall only be straight drops to diffusers.
- d. Ensure that good air distribution and occupant comfort are achieved through appropriate air outlet application, selection and location.
- e. Provide adequate access for internal inspection and cleaning of all ductwork. Access through diffusers, grilles or duct mounted access doors are to be provided at a minimum of 4 m (13 feet) intervals and at every floor in the case of risers.
- f. Minimum duct size for fire dampers to be 150mm (6").
- g. Provide locking nuts on all balancing dampers.

8. Electrical Rooms

- a. Electrical rooms are to be maintained at positive pressure to prevent dust from entering the room.
- b. Temperature in electrical rooms to be maintained at approximately 30°C (86°F).

5.16.12 Packaged Terminal Air Conditioning Systems

1. For rooms requiring year-round 24/7 cooling such as Data Rooms and Server Rooms, provide packaged terminal air conditioning systems if the building ventilation system is not otherwise required to operate 24/7.
2. Packaged terminal air conditioning units to be complete with remote air-cooled glycol dry cooler unit and to have no CFC's.

5.16.13 Variable Frequency Drives (VFD)

- a. Refer to electrical section 5.17.7.6

5.16.14 Motors for VFD Applications

- a. Refer to electrical section 5.17.7.7

5.16.15 Miscellaneous Exhaust Systems

2. General

- a. Ductwork shall be fabricated from galvanized steel or stainless steel depending on application.
- b. Use corrosion resistant materials for exhaust ducts conveying corrosive fumes and vapors, or where condensation is likely to occur.

3. Equipment Discharges

- a. Ensure that exhaust air is not exhausted into outdoor air intakes.

4. Fume Hood Exhaust

- a. Refer to “Laboratory Design Standards” Section 6.3.6. & 6.3.6.5

5.16.16 Fire and Life Safety Systems

Refer to section 5.22 Life Safety Systems

5.16.17 Storm Water Management

1. Storm water Collection, Conveyance and Treatment Systems

- a. Storm water management systems for all new development and major renovations on campus will manage on site the runoff for the 98th percentile rainfall event using low impact development (LID) measures and green infrastructure (GI). The 98th percentile rainfall event for the City of Calgary is 31mm over 24 hours.
- b. New buildings and building additions may incorporate, upon review and approval, a rainwater harvesting system to capture runoff volume from the 98th percentile rainfall event. Harvested rainwater shall be used for approved uses including irrigation and/or toilet flushing.
 - (i) *Rainwater harvesting system design shall follow the following technical guidelines: (1) the City of Calgary LID Guidelines, Module 5 - Rainwater Harvesting and Reuse, and (2) The City of Calgary Rainwater Harvesting Guidelines: For Internal Non-Potable Use*
 - (ii) *Detailed information on codes and standards, contained in the City of Calgary Rainwater Harvesting Guidelines: For Internal Non-Potable Use shall be followed in the design of rainwater harvesting systems*
 - (iii) *Sizing of cisterns/tanks for rainwater harvesting systems shall be based on water balance analysis. The tools used for cistern/tank sizing shall include (1) the City of Calgary Water Balance Spreadsheet, and (2) Sizing tables available in the City of Calgary LID Guidelines, Module 5 - Rainwater Harvesting and Reuse. For irrigation*



- use, cistern withdrawal shall be based on 25mm/week over irrigation area for a 16-week period or other appropriate value as determined by the landscape architect and irrigation consultant.*
- c. All new buildings and building additions shall incorporate an area of absorbent landscaping, equivalent to an 8 meter buffer around the building perimeter. Absorbent landscaping shall have a minimum depth of 300mm of absorbent topsoil with 25% permeability.
- (i) *Storm water runoff from all non-building impervious areas in the contributing sub-catchment shall be routed to absorbent landscaping.*
- (ii) *Priority landscape improvements shall be implemented as stipulated in the most recent version of the University of Calgary Integrated Storm water Management Plan and University of Calgary Landscape Master Plan.*
- (iii) *Bio filters (bio retention areas and bios swales) shall be implemented as stipulated in the University of Calgary Landscape Master Plan and as required on development sites to effectively manage on site the runoff for the 98th percentile rainfall event.*
- (iv) *Design and construction of bio retention areas, bios wales and absorbent landscaping shall follow the City of Calgary LID Guidelines, Module 2 - Vegetative Practices.*
- (v) *Prior to LID implementation, geotechnical and hydrogeological investigations shall be conducted to follow the requirements in the City of Calgary LID Guidelines, Module 1 - Geotechnical and Hydrogeological Considerations.*
- d. Other storm water management approaches which meet the requirements of section 5.16.17.1(a) above and the Service Delivery Goals of the University of Calgary Integrated Storm water Management plan may be considered if sufficient supporting analysis demonstrating their equivalency is produced by the design team. Any alternative approach to storm water management requires approval by University of Calgary.
- e. All storm water collection, conveyance and treatment systems should be designed and constructed in accordance with the latest editions of the City of Calgary Design Guidelines for Subdivision Servicing. The City of Calgary Standard Specifications for Sewer Construction, the City of Calgary Storm water Management & Design Manual, Amendments, and the City of Calgary LID technical Guidelines; except as amended below.

City of Calgary Design Guidelines for Subdivision Servicing Amendments

• Approvals

All references for approval by the City of Calgary or City departments shall be replaced with the University of Calgary except where work is connecting to infrastructure owned and operated by the City of Calgary.

• Wastewater and Storm water D. Mains and Services 2. Sizing add text to read:

“Storm sewer catchment areas, mains sizes and layout shall be in accordance with the most recent version of the University of Calgary Integrated Storm water Management Plan.”

- Wastewater and Storm water I. Storm water Management and Design, revise the text in a) to read:

“Storm water management design for landscaped/open space areas should indicate the need for catch basins and leads to intercept overland flows entering open space areas.

- Wastewater and Storm water I. Storm water Management and Design, revise the text in c) to read:

“Please refer to the most recent version of the City of Calgary LID Guidelines and Storm water Source Control Practices Handbook.”

- Wastewater and Storm water J. Erosion and Sediment Control and Construction Storm water Pollution Prevention, remove b. and revise a. to read:

“Prior to commencements of soil disturbance, Erosion and Sediment Control (ESC) reports and drawings must be prepared and submitted to University of Calgary for review.”

(ii) City of Calgary Standard Specifications Sewer Construction Amendments

- Approvals

All references for approval by the City of Calgary or City department shall be replaced with the University of Calgary except where work is connecting to infrastructure owned and operated by the City of Calgary.

(iii) City of Calgary Storm water Management and Design Manual Amendments

- Approvals

- All references for approval by the City or City department shall be replaced with the University of Calgary except where work is connecting to infrastructure owned and operated by the City of Calgary.

- Chapter 1, Storm water management and planning, Section 1.4 – Planning Levels, refer to the latest version of University of Calgary Integrated Storm water Management Plan

- Chapter 2, Authorization and Processes, Section 2.1 General, replace text of second paragraph to read:

- The designated consultant is responsible preparing the application and required information, which must be forwarded to University of Calgary. Construction of work is not permitted without the necessary permits and authorizations in place.

- Chapter 2, Authorization and Processes, Section 2.4, replace text to read:

Municipal by-laws and permitting apply at tie-ins to City of Calgary infrastructure and boundaries of University of Calgary

- Chapter 3, Storm water Design, add text to read:

- Level of service, minor system sizing and layout shall be in accordance with the most recent version of University of Calgary Integrated Storm water Management Plan.
- Low Impact Development (LID) and Best Management Practices (BMP) used for storm water servicing shall be in accordance with the most recent version of University of Calgary's Integrated Storm water Management Plan.
- Chapter 4, Development Site Servicing Plans, add text to read:
 - Level of service, minor system sizing, and layout, runoff volume control targets shall be in accordance with the most recent version of University of Calgary's Integrated Storm water Management Plan.
 - Low Impact Development (LID) and Best Management Practices (BMP) used for storm water servicing shall be in accordance with the most recent version of University of Calgary Integrated Storm water Management Plan.
- Chapter 8, Best Management Practices, add text to read:
 - Design and construction of any Low Impact Development (LID) and/or Best Management Practices (BMP) used for storm water servicing shall be in accordance with the most recent version of the University of Calgary Integrated Storm water Management Plan and The City of Calgary LID Technical Guidelines.
- Chapter 11, Technical Requirements, the applicable section is Section 11.1.8, Development Site Servicing Plans. If Storm water Management Report is required, it shall follow the additional technical requirements presented in subsection (iv) and include the following information:
 - site description
 - design objectives
 - criteria for storm system and LID/BMP sizing
 - allowable minor system discharges
 - rates and volumes of overland flow spills
 - plans, details, or cross sections depicting site conditions and LID/BMP strategies, highlighting topography, soil qualities, direction of water flow, and area of site that each strategy addresses
 - anticipated runoff volume from the 90th percentile rain fall event
 - LID/BMP location, sizing calculations (including runoff volume managed by each strategy), and design details

5.16.18 Water and Waste Water

1. Water Distribution and Waste Water Collection Systems

- a. All water distribution and wastewater collection systems should be designed and constructed in accordance with the latest edition of the City of Calgary Design Guidelines for Subdivision Servicing, City of Calgary Standard Specifications Sewer Construction, and City of Calgary Standard Specifications Waterworks Construction except as amended below.

(i) City of Calgary Design Guidelines for Subdivision Servicing Amendments

- Approvals

All references for approval by the City or City department shall be replaced with the University of Calgary except where work is connecting to infrastructure owned and operated by the City of Calgary.

- Waterworks B. Mains 1. Grid Network revise the text in c) to read

“Demands and minimum main sizes shall be determined in accordance with the criteria outlined in most recent version of the University of Calgary Water and Sanitary Master Plan. Fire flow requirements for all renovations and new construction shall be calculated and submitted to the University in accordance with the latest edition of the Fire Underwriters Survey.”

- Waterworks B. Mains 1. Grid Network revise the text in g) to read

“Sizes and layout of water mains shall generally be in accordance with the most recent version of the University of Calgary Water and Sanitary Master Plan.”

- Waterworks E. Service Connections 6. Meters add new section to read

“All new water services are to be metered. Meter sizing is to be determined in accordance with AWWA M22 Sizing Water Service Lines and Meters with calculations to be provided to the University. Meter make and model to be confirmed with the University.”

- Wastewater and Storm water D. Mains and Services 2. Sizing add text to read

“Main sizes and layout shall be determined in accordance with the most recent version of the University of Calgary Water and Sanitary Master Plan.”

- Wastewater and Storm water G. Sanitary Sewer Flows

“Sanitary sewer flows shall be determined in accordance with the criteria outlined in the most recent version of the University of Calgary Water and Sanitary Master Plan.”

(ii) City of Calgary Standard Specifications Sewer Construction

- Approvals

All references for approval by the City or City department shall be replaced with the University of Calgary except where work is connecting to infrastructure owned and operated by the City of Calgary.

(iii) City of Calgary Standard Specifications Waterworks Construction

2. Plumbing Piping Systems

- a. Any unused piping during demolition should be removed back to the source, capped and valved. Piping should never be abandoned in place, regardless of circumstances.
- b. All plumbing and drainage piping is to be designed with a lay-out that avoids piping



installed over electrical panels or other electrical equipment that would sustain damage in the event of piping leaks.

- c. Water and wastewater systems to be designed and installed without concealment of mechanical compression style joints (i.e. Labline).
- d. Domestic water supply must have a minimum system pressure of 140 kPa (20 psi) on the top floor of a building except for floors with flush valves, which would require 175 kPa (25 psi).
- e. Provide non-freeze key operated hose bibs every 30 m (100 feet) at the building perimeter.
- f. All water fountains shall be provided with a stainless steel backing, to protect wall materials and facilitate cleaning. Backing should start from baseboard and extend two feet over the fountain.
- g. All grooved piping systems for use with copper tubing shall be manufactured to copper-tube dimensions. (Flaring of tube or fitting ends to accommodate alternate sized couplings is not permitted.)
 - i. The couplings shall be Victaulic Style 607H, installation-ready, for direct stab installation without field disassembly.
 - ii. Gaskets shall be UL classified in accordance with ANSI / NSF-61 for potable water service.
- h. PEX piping which is exposed to any lighting (natural or artificial) is not permissible due to UV deterioration. Other alternatives should be considered to meet the application.
- i. Piping products shall comply with NSF-372.
- j. Provide isolation valves, in accessible locations, on:
 - i. Supply and return mains
 - ii. Bottom of each riser
 - iii. Branch lines from mains
 - iv. Each washroom group
 - v. Individual fixtures
 - vi. Non-freeze hose bibs
- k. Refer to Appendix C for pipe and fitting materials list.

3. Plumbing Fixtures

- a. Refer to Appendix B – List of Acceptable Plumbing Fixtures.
- b. Low flow fixtures must be utilized.
 - i. Standard water closets shall not exceed 4.8 Litres per flush (LPF).
 - ii. Dual-flush water closets shall not exceed 6/4.2 LPF.
 - iii. Urinals shall not exceed 0.5 LPF.



- iv. Lavatory faucets shall not exceed 1.9 Litres per minute (LPM)
 - v. Showers shall not exceed 6.8 LPM
 - vi. Waterless urinals are not acceptable.
 - vii. Flush valves to be piston type.
 - viii. Provide faucets with laminar flow/stream aerators
 - c. Provide eyewash and/or safety showers in areas where exposure to/or contact with corrosive chemicals may occur. Possible locations include laboratories and battery recharge operation.
 - d. Provide tempered potable water to eyewash and safety showers.
4. Non-Potable Water System
- a. All non-potable water piping to be in accordance to CSA B128.1-06 / B128.2-06.
 - b. All non-potable water piping shall be marked with "Warning: Non-potable water – Do not drink." Markings to be in purple colour or pipe to be continuously painted in purple.
5. Storm Drainage Piping System
- a. Provide minimum 100 mm (4") roof drains.
 - b. Provide a minimum of two roof drains per drainage area.
 - c. At the end of each major construction project, the storm system is to be inspected and cleaned out from construction debris.
6. Sanitary Sewer Piping System
- a. Sanitary floor drains shall be provided in multi-toilet fixture washrooms, mechanical equipment rooms, and locations where interior floor drainage accumulates wastes. Single fixture washrooms do not require floor drains.
 - b. Cleanouts are to be located at a minimum of 330 mm (one foot) above flood rim levels of plumbing fixtures (water closets, urinal and sinks).

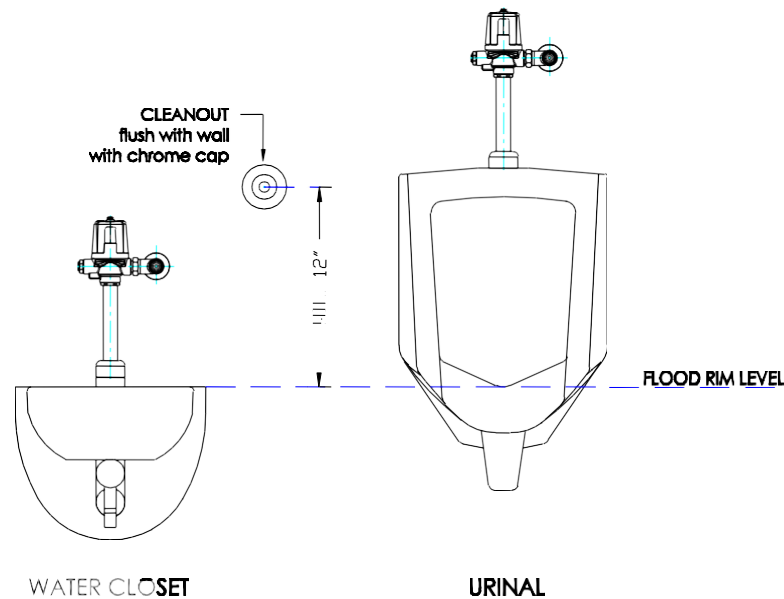

- c. Sanitary and storm piping below grade that is bedded on fill, as opposed to unexcavated soil, such that it would be subject to settlement is to be hung from the slab. Refer to figure below.

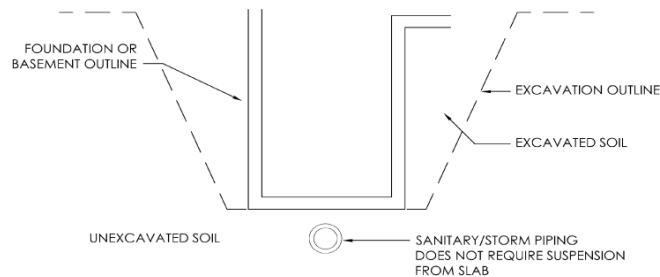

- d. Provide grease interceptors in kitchens where drains and fixtures discharge fat, oil and grease laden waste. Grease interceptors are not required in residential type kitchen.
- e. Provide sand/oil separator in vehicle repair garages.
- f. Provide sampling manhole in sanitary sewer line in facilities containing laboratories.
- g. Ensure sanitary waste discharge from laboratories complies with local codes, environmental and health regulations.
- h. Provide appropriate traps or interceptors for sinks in areas such as occupational therapy, cast, photo developing, and hairdressing.
- i. Emergency fixtures such as combination eyewash / shower stations to be provided with own dedicated floor drain. Eyewash basin must be directly piped to sanitary.
- j. Provide large laboratory areas with acid waste drainage to a neutralizing sump. Sump to

be equipped with pH probe and meter.

- k. Provide small laboratories or isolated laboratories with point-of-use dilution or neutralizing traps.
- l. All acid neutralization tanks or systems using limestone or not (chemical injection type) will need solids interceptors upstream them.
- m. Use chemically and fire resistant piping (LABLINE) in drainage systems serving laboratories where acids are used or photo processing is provided.
- n. "Fuse seal" or continuous piping is allowed in concealed locations.
- o. Provide a removable screen at trench drain discharge points to prevent debris from plugging piping. Trench drains subject to freezing at overhead doors to be heattraced.
- p. At the end of each major construction project, the sanitary system is to be inspected and cleaned out from construction debris.
- q. Any food kiosk or operation in campus MUST comply with City of Calgary waste bylaw 14M2012 (refer below for a section of this bylaw). Pantry sinks in new buildings and renovations where heavy usage are expected should comply with this bylaw.
- r. An owner of a restaurant or other premises that is connected directly or indirectly to the wastewater system, and where food is cooked, processed or prepared, must do all of the following:
 - i. Install a FOG interceptor at a directly accessible location on the upstream side of a monitoring access point in or on the premises that is designed and sized in accordance with CAN/CSA B481, and meets the requirements of the National Plumbing Code of Canada to prevent FOG from passing into the wastewater system;
 - ii. Monitor, operate, properly maintain at all times, and clean each FOG interceptor installed in or on the premises in accordance with the requirements set by CAN/CSA B481 and in compliance with the manufacturer's instructions and specifications;
 - iii. Ensure that no wastewater exceeds the maximum allowable concentration limits for FOG, as set out in Schedule "C" of this Bylaw.

7. Water Filtration and Treatment

- a. No domestic water filtration and treatment required unless specifically requested by the University.

8. Domestic Hot Water

- a. General
 - i. Provide domestic hot water recirculation piping complete with balancing valves where hot water supply piping exceeds 15 m (50 feet). Branch piping from a manually operated faucet to a circulated main shall not exceed 8 m (25 feet), or 3 m (10 feet) for a hands free faucet.
 - ii. Provide additional isolation valves on recirculating system to prevent total system isolation of recirculating piping should leaks or other problems arise.

- iii. Provide flow-measuring valves for each major branch of the domestic hot water recirculation system.
 - iv. Provide cathodic protection (sacrificial anode) on all Domestic water tanks.
 - b. Connection to Campus Utility Infrastructure
 - i. Refer to Section 1.11 for high temperature hot water connection to Service Tunnel services.
 - ii. The low temperature hot water for building heating is to be used for generation of domestic hot water through shell and tube heat exchangers.
9. Backflow Prevention
- a. Provide backflow prevention to plumbing code requirements.
 - b. On the main water service, install parallel-approved backflow prevention devices to ensure water availability during testing and maintenance. Piping size must remain constant for both devices and of same diameter as main supply piping.
 - c. Provide backflow prevention devices on domestic cold and hot water piping to a laboratory or group of laboratories. Piping downstream of backflow devices to be labelled as “non-potable.”
 - d. Where a building contains more than five laboratories, locate the cold and hot water backflow prevention devices centrally, and pipe “non-potable” cold and hot water to all laboratories. Emergency fixtures to be supplied with potable water.
 - e. Backflow preventers to be indirectly connected to floor drain.
 - f. Backflow preventers to be readily accessible for maintenance. No backflow preventer installation shall be made above ceilings, in confined spaces, or in spaces that are not regularly supervised when RPA’s are installed, nor in spaces where adequate area drainage is not readily present.
 - g. Backflow preventers and vacuum breakers shall be adequately supported and restrained to prevent lateral movement. Installation accessories, such as pipe hangars, braces, saddles, stanchions, and piers, shall be used to support backflow preventers and vacuum breakers and shall be placed in a manner that will not obstruct access to the device for testing and maintenance or interfere with the operation of the relief valve(on RP type backflow preventers)
 - h. Bypasses around backflow preventers or vacuum breakers shall be prohibited, except where and equivalent backflow preventer is installed on the bypass. The bypass backflow preventer shall be installed on systems that require 24/7 uninterrupted service and shall remain of full line size equivalent.
 - i. Except when the device is installed within an enclosure that complies with ASSE 1060, the minimum clearances specified in Table below, or the manufacturer’s recommendations, whichever are greater, shall be used when installing backflow preventers or vacuum breakers.

Clearances, mm

Type of device	Centreline height above the floor		Minimum clearance			
	Minimum	Maximum*	Between the bottom of the relief valve and the floor	Above the device	In front of the device†	Behind the device†
DCVA	750	1500	—	300	750	20
DCVAF	750	1500	—	300	750	20
PVB	—	1500	—	300	750	20
RP	750	1500	300	300	750	20
RPF	750	1500	300	300	750	20
SCVAF	750	1500	—	300	750	20
SRPVB	—	1500	—	300	750	20

*Installations with a greater centreline height may be used if provided with a fixed platform.

†To the nearest wall or obstruction.

Notes:

(1) An em-dash (—) indicates that there is no requirement specified in this Standard.

(2) Clearances might have to be increased for backflow preventers with side-mounted test cocks or relief valves or when the sight tube method of testing is used.

5.16.19 Natural Gas
1. General

- a. All natural gas piping to be in accordance to CAN/CSA B149.1-2005
- b. Provide drip points:
 - i. At low points in piping system.
 - ii. At connections to equipment.
 - iii. All new labs or major Reno is requiring natural gas should be provided with an emergency shut-off solenoid valve and mushroom type push button in close proximity to the lab exit. Push bottom should be keyed type for resetting purposes. Natural gas solenoid valve shall fail closed in a power outage and remain closed when power is re-established. Only operations personal can have a key to reset solenoid valves.

5.16.20 Testing of Piping
1. General

- a. Test system in accordance with the latest codes and requirements of authorities having jurisdiction.

5.16.21 Service Tunnel
1. General

- a. The Central Plant will provide the following utilities through a distributed system of



underground tunnels.

- i. High temperature water supply at 2760 kPa (400 psi) and 204°C (400°F) for hot water, low-pressure steam and domestic water heating.
 - ii. Chilled water supply at 1034 kPa (150 psi) and 4.4°C (40°F) for cooling.
 - iii. Chilled water return at 12.8C (55°F).
 - iv. Treated feed water at 827 kPa (120 psi) and 93°C (200°F).
 - v. Compressed air for automatic control systems at 758 kPa (110 psi).
 - vi. Domestic cold water
 - vii. Natural gas
- b. Consultants are required to provide building loads to Chief Operating Engineer for connection to tunnel services. The Chief Operating Engineer will in turn supply these utilities to the building perimeter.
 - c. All piping and metering of services from the service tunnel to the building perimeter will be done by the Utilities Division. Stub-ins of each service will be provided at the building perimeter at a location mutually agreed to between Chief Operating Engineer and the Consultant. The utility service lines will be designed, supplied and installed up to the perimeter of the Utilities Division.
2. High Temperature Vault
 - a. Provide two means of egress from the high temperature vault.
 - b. The high temperature vault to house the following:
 - i. HTHW to LTHW heat exchangers
 - ii. HTHW to Steam heat exchangers
3. High Temperature Hot Water
 - a. High temperature hot water, abbreviated HTHW, is generated in the Central Heating and Cooling Plant where it is distributed throughout the main utility tunnel system.
 - b. The distribution is a two-pipe supply and return system.
 - c. Connection to the tunnel system can be made at any point along the tunnel piping, with limitations.
 - d. All branch connections to be parallel. Connection must be made to both supply and return piping in the main tunnel.
 - e. The high temperature hot water is never to be consumed at any point and is never to be exposed to any other fluid. It is solely to be used as a heating medium within a heat exchanger.
 - f. The high temperature hot water is to flow inside the tubes in shell and tube heat exchangers.



- g. All branch connections made to the piping in the main tunnel must be valved. Isolation valves are to be installed in the main on both sides of the branch.
- h. By-pass valves for filling and pressurizing are to be provided around all main tunnel shut-off valves. Drain and vent valves to be provided on building supply and return legs.
- i. Connection to the main utility lines shall be made at the time specified by the Chief Operating Engineer, the University of Calgary. Shut down and the Chief Operating Engineer cutting shall do draining of lines to accommodate.
- j. The maximum permissible pressure drop between supply and return connection to the high temperature hot water lines in the main tunnel (including all piping, equipment and controls) is regulated at 157 kPa (23 psi).
- k. The maximum allowable working pressure of HTHW piping to be 2760 kPa (400 psi). The secondary piping in the building to have maximum allowable working pressure of 1035 kPa (150 psi) and 104°C (220°F).
- l. Refer to drawing M-1 for typical HTHW Vault Component Layout.
- m. All HTHW piping to be welded and 100% x-rayed.
- n. High temperature hot water piping to be designed to ASME standard B31.3, process piping.
- o. Welders must have a valid QC programs with ABSA. HTHW two-way control valves should always fail closed.

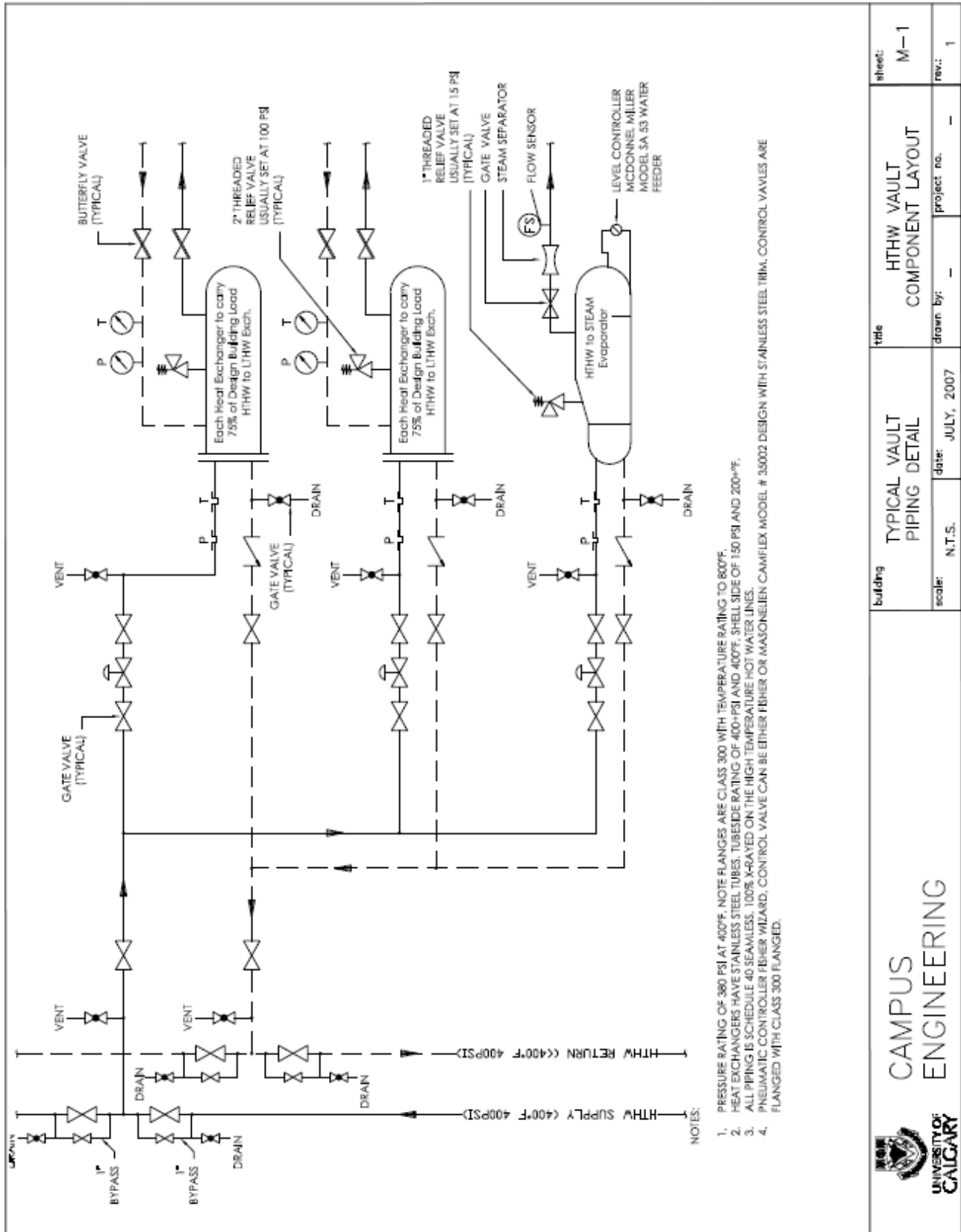

<p>CAMPUS ENGINEERING</p>	<p>building</p> <p>TYPICAL VAULT PIPING DETAIL</p>	<p>title</p> <p>HTHW VAULT COMPONENT LAYOUT</p>	<p>sheet:</p> <p>M-1</p>
	<p>scale:</p> <p>N.T.S.</p>	<p>date:</p> <p>JULY, 2007</p>	<p>drawn by:</p> <p>-</p>
			<p>rev.:</p> <p>1</p>



4. Chilled Water

- a. Chilled water for cooling is generated in the Central Heating and Cooling Plant where it is distributed throughout the main utility tunnel system.
- b. The distribution is a two-pipe supply and return system.
- c. Connection to the tunnel system can be made at any point along the tunnel piping, with limitations.
- d. All branch connections are parallel. Connection must be made to both supply and return piping in the main tunnel.
- e. The chilled water is never to be consumed at any point and is never to come in contact with any other fluid. It is solely to be used as a chilling medium within a heat exchanger or a coil.
- f. Circulation of chilled water within a building to be accomplished by secondary pumping to overcome the friction head of building circuits and to hold the supply and return temperature differential to 15°F (minimum of 10°F differential).
- g. Refer to drawing M-2 on page 26 for chilled water connection detail.

5. Treated Feed Water

- a. Treated feed water for the filling of Low Temperature Hot Water Heating Systems and make-up to steam generating systems, is supplied from the Central Heating and Cooling Plant throughout the main utility tunnel system.
- b. The water is supplied through the tunnel under pressure in a single pipe looped system.
- c. Connection to this system can be made at any point along the tunnel piping.
- d. All branch connections made to the piping in the main tunnel must be valved. Isolation valves are to be installed in the main on both sides of the branch.
- e. The feed water is softened, deaerated, treated to prevent corrosion, and controlled at a pH approximately 8.0.
- f. Temperature of the water as it leaves the Central Heating and Cooling Plant is approximately 93.3°C (200°F).
- g. The feed water is supplied at a pressure of 827 kPa (120 PSI) which will be adequate for pressurizing systems in most of the buildings on Campus. Exceptionally tall buildings will require the service of a pressure booster pump.
- h. Treated feed water piping must be clearly marked throughout its entirety as per international piping marking standards, ASNI A13.1.
- i. Refer to drawing M-2, on next page, for typical HTHW Vault Component Layout.

6. Pneumatic Control System

- a. Compressed air, for automatic control and instrument service, is supplied from the



Central Heating and Cooling Plant and distributed through the main tunnel system. It is to be used, unmetered, for automatic control service in all existing buildings.

- b. Compressed air supply in the main tunnel system is regulated at 758 kPa (110 psi). It is chemically dried, filtered and oil free.
- c. Connection from the main tunnel piping is to include two shut off valves in the main on either side of the service branch and a shut off valve and check valve in the service branch.
- d. Pressure is to be reduced for building requirements by the installation of spring loaded, self-contained, diaphragm type pressure regulators.
- e. Compressed air piping for use as control air must be clearly marked throughout its entirety as "Control Air" so as not to be confused with compressed air for laboratories or other compressed air uses.
- f. Refer to drawing M-2 for typical HTHW Vault Component Layout.

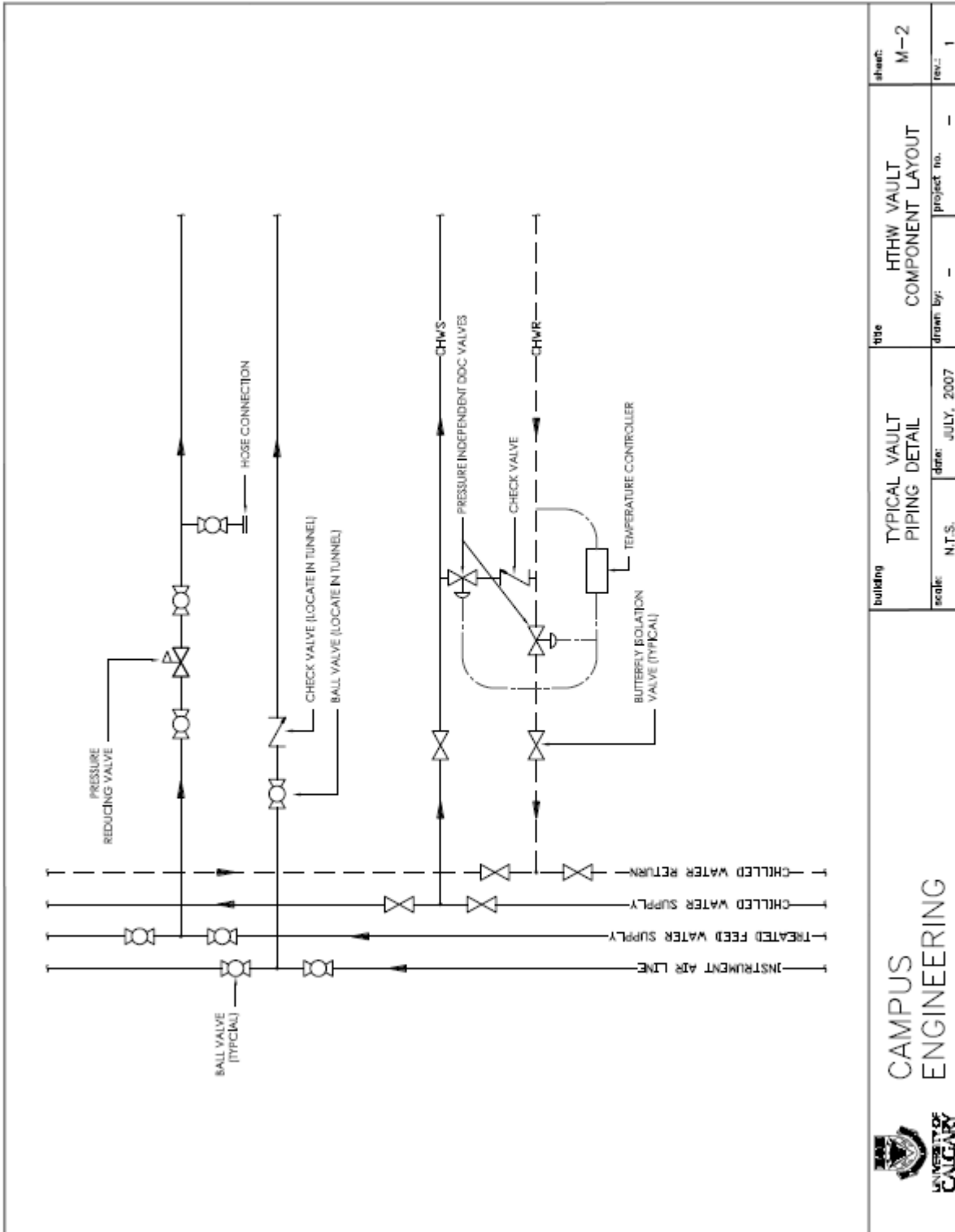

CAMPUS ENGINEERING

building	title	sheet
TYPICAL VAULT PIPING DETAIL	HTHW VAULT COMPONENT LAYOUT	M-2
scale: N.T.S.	drawn by: -	rev.: 1
date: JULY, 2007	project no. -	



5.16.22 Noise and Vibration Control

1. Background Noise

- a. Consider impact of mechanical noise on nearby residences or other noise-sensitive properties. Silence or strategically locate outdoor mechanical equipment or intake/exhaust openings to meet City noise bylaw requirements. For remote facilities, in the absence of a noise by-law design systems to a maximum noise level of 55 dB(A) at the facility property line.
- b. Locate rooftop equipment over corridors or other non-critical areas; avoid placing equipment over instructional space. (If required for external review, have available any details describing acoustic treatment, duct configuration and roof penetrations for any rooftop installations.)
- c. Locate mechanical room or main air handling equipment away from noise sensitive areas such as instructional spaces. Ensure large equipment is equipped with vibration isolation hardware appropriate to its location.
- d. Avoid locating duct shafts in classrooms.
- e. Use masonry construction for large mechanical shaft walls that are common to occupied spaces.

2. Ducts, Terminal Devices and Silencers

- a. Locate an in-duct silencer within the mechanical room as close as possible to the wall that the duct penetrates. For walls that are not fire rated, part of the silencer should penetrate the wall.
- b. Maintain adequate spacing between duct wall and the nearest wall(s): the clearance should equal 10% of the duct's larger dimension OR 150 mm (6"), whichever is larger.
- c. Whenever possible, design the system layout so that any medium velocity ducts and terminal boxes are in non-instructional areas such as corridors.
- d. Use flexible connections between fans, plenums and all related ductwork.
- e. Provide smooth airflow conditions near the fan units to minimize air turbulence. Large, rectangular ductwork with medium and high air velocities can create low frequency duct rumble. Spiral-wound, round duct is preferred for air velocities over 9 m/s (1785 ft. /min) or where excessive turbulence is anticipated.
- f. Select terminal box on basis of both in-duct and radiated noise level. Manufacturer's VAV box noise data often assumes the equipment is located above a mineral fibre suspended ceiling and assumes the use of acoustically lined duct. Ensure that design conditions correspond with these requirements.
- g. Provide 900 mm (36") of acoustically lined ductwork or silencer after VAV box. Any supply air take-offs are to be installed after lined ductwork.
- h. Suspend terminal box and other similar equipment independently from deck above (do not permit to rest on suspended ceiling grid).



- i. Plan separate supply feeder duct into each room from main supply trunk over corridor (one common trunk-duct directly above rooms with short take-off(s) into each room is unacceptable).
- j. Select diffusers/air outlets so that the combined sound from all diffusion in a room meets the design criterion. Noise from a single diffuser will typically need to be 6 - 10 dB lower than RC (N) criteria.
- k. Locate balancing damper at least 2 m (6 feet) upstream of diffuser/outlet.
- l. Provide at least 600 mm (24") of straight duct ahead of diffuser inlet.
- m. Provide bullhead tee connection for all ceiling diffusers.
- n. Placement of Return-Air grilles:
 - i. Where classroom or office doors are located immediately adjacent (along a Corridor) or directly opposite (across a Corridor), keep ceiling-mounted return-air grilles within the rooms as far apart as feasible or, in the case of a series of classrooms or offices, evenly spaced from one another. Return air grilles need not be directly above the room entry.
 - ii. Where a wall between a Classroom (or Office) and a Corridor continues above the ceiling to the roof-deck, openings in the wall above the ceiling for return-air need not be directly adjacent to the return-air grille in the classroom/office ceiling. Even distribution along the Corridor is suggested. For particularly noise-sensitive areas, include a sound trap (Z- or L-shaped) in this opening; there should not be line-of-sight through the sound-trap.
- o. Where perimeter heat cabinets are planned, ensure the use of non-continuous cabinets that terminate at intersecting walls. Discontinue use of fins at all wall junctions and provide for a complete airtight seal where the heating pipe passes through the wall.

3. Piping Noise

- a. Use non-continuous perimeter heating cabinets that terminate at walls. Discontinue use of fins at all wall junctions. Provide a complete airtight seal where the heating pipe passes through wall.
- b. Use a resilient sleeve around supply pipes with oversized clamps fastened to structure, in areas where water flow noise may be a disturbance. Sleeves comprised of 12 mm (1/2") thick closed-cell elastomeric pipe insulation or proprietary resilient pipe fasteners are acceptable. Do not use hard plastic sleeves.
- c. Clamps supporting risers should be separated from the floor with a vibration isolator and should be oversized to accommodate a full surround isolating layer between pipe-wall and clamp.
- d. Ensure that pipes penetrating through drywall partitions are not rigidly connected to the structure. Provide a sleeve at the wall opening, leaving an air space around the pipe, and seal with a resilient caulking.
- e. Where double plumbing walls are used (e.g. washrooms), attach supply piping only to the fixture side of the wall structure.
- f. Consider the use of pressure reducing valves (PRV's) in the system to minimize



plumbing noise for noise sensitive areas. Size PRV's to limit the pressure at fixtures to 375 kPa (55 psi).

- g. Divide water supply lines at the riser with each room fed separately. Tee take-offs serving back-to-back fixtures in separate washrooms should be avoided.
- h. Install water hammer arrester adjacent to any quick-acting solenoid valves.

4. Vibration Isolation

- a. Use the current ASHRAE Applications Handbook as a general guide for selecting vibration isolators and concrete inertia bases.
- b. Locate rooftop mechanical equipment on a stiff portion of a lightweight roof to eliminate resonance problems. Vibration problems can usually be avoided if the static deflection of the spring isolator is at least 15 times the structural deflection of the roof caused by equipment loading. Coordinate with structural consultant.
- c. Locate emergency generators at grade level to avoid structural vibration problems.
- d. Provide vibration isolation for all rotating equipment.
- e. Isolator type to be indicated on the mechanical drawings.
- f. All suspended equipment with movable parts to be isolated from structure via neoprene or spring hangers.

5. Flexible Connections

- a. Use flexible connectors on pumps requiring vibration isolation from related piping. Twin sphere neoprene rubber flex connectors are the preferred type on chilled water systems. Steel braided pipe connectors are required on all heating systems (e.g. hot water heating, glycol heating, etc.)
 - i. On systems using grooved piping, three Victaulic flexible couplings may be used in lieu of flexible connectors for vibration attenuation. The couplings shall be placed in close proximity to the source of the vibration.
- b. Show all flexible connections on drawings.
- c. Use flexible connections between fans, plenums and all related ductwork.

5.16.23 Thermometers, Gauges and Air Flow Measuring Devices

1. Thermometers and Gauges

- a. All mechanical equipment shall be provided with instrumentation or test ports to verify critical parameters, such as capacity, pressures, temperatures and flow rates.
- b. Thermometers and pressure gauges are required on all pumps, chillers, boilers, heat exchangers, cooling coils, heating coils and cooling towers.
- c. Provide one pressure gauge per pump. Install taps before strainers and on suction and discharge of pump. Pipe to gauge with ball isolation valve on each tap.



- d. For gauges on liquid service, provide tee in piping with bronze pulsation damper and ball isolation valve.
- e. Install gauges between equipment and first fitting valve.
- f. Install gauges in locations and angles that are easily readable from normal sight.
- g. Provide extensions where pressure gauges or thermometers are installed through insulation.
- h. Install pressure / temperature taps into threaded pipe nipples welded to wall of pipe. Locate fittings in accessible spaces.
- i. Install pressure / temperature taps in the following locations:
 - i. Both sides of two-way control valves larger than NPS 30 mm (1¼").
 - ii. All lines to three way control valves.
 - iii. Heating and cooling coils (excluding terminal reheat coils): at inlet and outlet of each coil within multiple coil banks.
 - iv. Heat exchanges: at each inlet and outlet.
 - v. Chiller: at inlet and outlet of chilled water and condenser water.
 - vi. Individual return lines from heating and cooling coils.
 - vii. Omit pressure / temperature taps in locations where pressure gauges and thermometers are indicated.
- j. Install pressure gauges, thermometers, and air pressure gauge taps in the following locations:
 - i. Pressure Gauges
 - Both side of pressure reducing valves.
 - Pumps – suction and discharge.
 - Expansion Tanks.
 - Pressure Tanks.
 - Top of each standpipe riser.
 - Standpipe and sprinkler water supply connection.
 - Sprinkler system zone connection.
 - Domestic water supply to building.
 - Low-pressure steam service.
 - Inline water filtration.
 - ii. Stem Type Thermometers
 - Heat exchanges at each inlet and outlet.

- Equipment coil bans at each inlet and outlet.
 - Boilers at each inlet and outlet.
 - Chillers at each inlet and outlet.
 - Water zone supply and return mains.
 - After major coils – inlet and outlet.
- iii. Dial Type Thermometers:
- Each supply air zone.
 - After coils in air system.
 - Outside air intake.
 - Return air plenum.
 - Mixed air plenum.
- iv. Static Pressure Gauges:
- Supply fan discharge on medium and high-pressure systems.
- v. Differential Pressure Gauges:
- Across filter banks.
- vi. Static Pressure Taps:
- Inlet and discharge of supply and return fans.
 - Inlet and discharge of coils.
 - Inlet and discharge of silencers.
 - Inlet and discharge of mixing chambers.
 - Inlet and discharge of heat recovery sections.
2. Testing Stations
- a. Permanent or temporary testing stations shall be provided for startup and testing of building systems.
 - b. Connections shall be designed so temporary testing equipment shall be installed and removed without system shutdown.
3. Airflow sensors/stations
- a. Airflow measurement devices shall use the principle of thermal dispersion and provide one self-heated bead-in-glass thermistor and one zero power bead-in-glass thermistor at each sensing node.
 - i. Thermal dispersion devices that indirectly heat a thermistor are not acceptable.
 - b. Excluded devices:
 - i. Fan airflow measurement devices.



- ii. Vortex shedding airflow measurement devices.
- iii. Pitot tubes, pitot arrays, piezo-rings and other differential pressure measurement devices.
- c. Sensor Probes
 - i. Sensor probes shall be constructed of gold anodized, 6063 aluminum alloy tube
 - ii. Sensor probe mounting brackets shall be constructed of 304 stainless steel.
 - iii. Probe internal wiring between the connecting cable and sensor nodes shall be Kynar coated copper.
 - PVC jacketed internal wiring is not acceptable.
 - iv. Probe internal wiring connections shall consist of solder joints and spot welds.
 - Connectors of any type within the probe are not acceptable.
 - Printed circuit boards within the probe are not acceptable.
 - v. Probe internal wiring connections shall be sealed, protected from the elements, and suitable for direct exposure to water.
 - vi. Each sensor probe shall be provided with an integral, FEP jacket, plenum rated CMP/CL2P, UL/cUL Listed cable rated for exposures from -67°F to 392 °F (-55° C to 200° C) and continuous and direct UV exposure.
 - Plenum rated PVC jacket cables are not acceptable.
 - vii. Each sensor probe cable shall be provided with a connector plug with gold plated pins for connection to the transmitter.
 - viii. Each sensor probe shall contain one or more independently wired sensing nodes.
 - ix. Sensor node airflow and temperature calibration data shall be stored in a serial memory chip in the cable-connecting plug and not require matching or adjustments to the transmitter.
 - x. Each sensor node shall be provided with two bead-in-glass, hermetically sealed thermistors potted in a marine grade waterproof epoxy.
 - Devices that use epoxy or glass encapsulated chip thermistors are not acceptable.
 - xi. Each thermistor shall be individually calibrated at a minimum of 3 temperatures to NIST-traceable temperature standards.
 - xii. Each sensor node shall be individually calibrated to NIST-traceable airflow standards at a minimum of 16 calibration points.
 - xiii. The number of independent sensor nodes provided shall be as follows:

Area ft. ² [m ²]	# Sensor Nodes
≤ 0.5 [≤ 0.047]	1
> 0.5 & ≤ 1 [≤ 0.093]	2
> 1 & ≤ 2 [0.093 & ≤ 0.186]	4
> 2 & ≤ 4 [0.186 & ≤ 0.372]	6
> 4 & ≤ 8 [0.372 & ≤ 0.743]	8
> 8 & ≤ 12 [0.743 & ≤ 1.115]	12
> 12 & ≤ 14 [1.115 & ≤ 1.30]	14
> 14 [1.30]	16

xiv. A total of 4 probes shall be required for openings with an aspect ratio ≤ and with an area ≥ 25 ft.2 (≥ 2.32 m2).

d. Transmitter

- i. A remotely located microprocessor-based transmitter shall be provided for each measurement location.
- ii. The transmitter shall be comprised of a main circuit board and interchangeable interface card.
- iii. All printed circuit board interconnects, edge fingers, and test points shall be gold plated.
- iv. All printed circuit boards shall be electroless nickel immersion gold (ENIG) plated.
- v. All receptacle plug pins shall be gold plated.
- vi. The transmitter shall be capable of determining the average airflow rate and temperature of the sensor nodes.
 - Separate integration buffers shall be provided for display airflow output, airflow signal output (analog and network) and individual sensor output (IR- interface).
- vii. The transmitter shall be capable of providing a high and/or low airflow alarm.
- viii. The transmitter shall be capable of identifying an AMD malfunction via the system status alarm and ignore any sensor node that is in a fault condition.
- ix. The transmitter shall be provided with a 16-character, alphanumeric, LCD display.
 - The airflow rate, temperature, airflow alarm and system status alarm shall be visible on the display.
 - The transmitter shall be provided with two field selectable (0-5/0-10 VDC or 4-20mA), scalable, isolated and over-current protected analog output signals and



hardwired to the BMS pane.

- x. Analog output signals shall provide the total airflow rate and be field configurable to output one of the following:
 - Temperature
 - Airflow alarm; or
 - System status alarm
 - xi. Network communications shall provide the average airflow rate, temperature, airflow alarm, system status alarm, individual sensor node airflow rates and individual sensor node temperatures.
 - xii. The transmitter shall be powered by 24 VAC and use a switching power supply that is over-current and over-voltage protected.
 - xiii. The transmitter shall use a “watchdog” timer circuit to ensure continuous operation in the event of brownout and/or power failure.
- e. Performance
- i. Each sensing node shall have an airflow accuracy of $\pm 2\%$ of reading over an operating range of 0 to 5,000 FPM (25.4 m/s).
 - ii. Each sensing node shall have a temperature accuracy of $\pm 0.15^\circ$ F (0.1° C) over an operating range of -20° F to 160° F. (-28.9° C to 71° C).

5.16.24 Thermal Insulation

1. General

- a. All insulation materials shall comply with the fire and smoke hazard ratings in accordance with CAN/ULC-S102 and NFPA 255. Accessories such as adhesives, mastics, cements and tapes shall have the same or better fire and smoke hazard ratings.
- b. Insulation shall be provided in accordance with ASHRAE Standard 90.1 -2013. Insulation that is subject to damage or reduction of thermal resistivity if wetted shall be enclosed with a vapour barrier jacket.

2. Duct Insulation

- a. All supply air ducts must be insulated in accordance with ASHRAE Standard 90.1-2013. Supply air duct insulation shall have a vapour barrier jacket. The insulation shall cover the duct system with continuous, unbroken vapour seal.
- b. Return and exhaust air distribution system shall be insulated in accordance with ASHRAE Standard 90.1 -2013. The insulation of return and exhaust air distribution systems needs to be evaluated for each project and for each system to guard against condensation formation and heat gain/loss on a recirculating or heat recovery system. Generally, return and exhaust distribution systems do not require insulation if located in a ceiling plenum or mechanical room used as a return air plenum.
- c. All duct insulation shall be formaldehyde free as validated by UL/E, contain a minimum 50% recycled content and be Deca-BDE free.

3. Equipment Insulation
 - a. All equipment, heat exchangers, converters and pumps shall be insulated in accordance with ASHRAE Standard 90.1-2013.
 - b. All equipment and piping in high temperature vault and tunnels to be aluminum jacketed.
4. Pipe Insulation
 - a. All pipe systems shall be insulated in accordance with ASHRAE Standard 90.1 -2013.
 - b. All pipe insulation shall be formaldehyde free as validated by UL/E and shall contain a minimum 50% recycled content.
 - c. All pipe system with surface temperatures below average dew point temperature of the indoor ambient air and where condensate drip will cause damage or create a hazard shall be insulated with a vapour barrier to prevent condensation formation regardless as to whether pipe is concealed or exposed.
 - d. Chilled water pipes shall be insulated with non- permeable insulation such as cellular glass. (specify a glass wool product with factory applied VentureClad jacket having a “0” perm rating as per ASTM E 96-05.
 - e. All exposed piping (within the building envelope) shall have PVC jacketing in non-service spaces, and canvas jacketing in service spaces.
 - f. Non-potable and tempered water piping shall be insulated.
5. Thermal Pipe Insulation for Plumbing Systems
 - a. Pipe insulation shall be ULC Classified.
 - b. Satisfy ASTM C 547: Type I and Type IV.
 - c. Does not exceed 25 flame spread and 50 smoke developed per CAN/ULC S102-M88.
 - d. All domestic water pipes shall be insulated in accordance with ASHRAE Standard 90.1 - 2013.
 - e. All piping exposed and concealed shall be insulated to prevent condensation.
 - f. All exposed piping shall have PVC jacketing in non-service spaces, and canvas jacketing in service spaces.
 - g. All sanitary sewer vents terminating through the roof shall be insulated for a minimum of 3 m (10 feet) of roof outlet.
 - h. All roof drains and storm sewer pipes shall be insulated in their entirety in the horizontal position just below the roof.
6. Insulation thickness to exceed the minimum requirements of the MNECB.
7. All live steam lines inside air handling units (e.g. steam humidification supply headers) shall be insulated

5.16.25 Identification of Mechanical Systems

1. General

- a. All equipment, valves, pipes, ducts and building automation system components shall be identified to University of Calgary Standards.
- b. Paints and coatings must not exceed the volatile organic compound (VOC) content limits established in Green Seal Standard GS-11, Paints, First Edition, May 20, 1993.

2. Equipment Nomenclature

a. New Buildings

- i. All mechanical equipment for new construction shall be numbered sequentially within each equipment type: e.g. AHU-1, 2, 3, CWP-1, 2, 3, UH-1, 2, 3 etc. Variable frequency drives for fans and pumps shall be numbered to match the equipment they serve (e.g. VFD-AHU-1, 2, 3, VFD-P-1, 2, 3 etc.).

b. Renovations / Expansions

- i. For renovation and expansion projects equipment numbering sequence shall begin with a 3 digit series number to identify new equipment installed for a specific project (e.g. AHU-101,102,103, CWP-101, 102, UH-101,102 etc.) Check with Facilities Management to determine the series to sue for the project. (e.g. 100, 200, or 300 etc.)

3. Equipment Identification

- a. All equipment shall be complete with the manufacturer's nameplate and equipment nameplate.

b. Manufacturer's Nameplates

- i. Nameplates shall be mechanically fastened to each piece of equipment.
- ii. Lettering shall be raised or recessed.
- iii. All name plates shall include the following as appropriate:
 - Manufacturers name, model, size, serial number and capacity.
 - Motor voltage, frequency, phase, power factor, duty and frame size.

c. Equipment Nameplates

- i. Equipment nameplates shall have white letters with black background.
- ii. Nameplates shall be 3 mm (1/8") thick laminated plastic, matte finish, with square corners, letters accurately aligned and machine engraved into core.
- iii. Lettering size to be:
 - Terminal cabinets and control panels: 8 mm (5/16") high lettering.
 - Equipment in mechanical rooms and outdoors: 20 mm (13/16") high lettering.
 - Equipment located elsewhere: 12 mm (1/2") high lettering.

- iv. When appliances and equipment are to be insulated, manufacturer equipment nameplates are not to be concealed.

4. Valve Identification

- a. All valves, except those in plain sight of equipment served, shall be tagged with brass tags.
- b. Brass tags are to be 40 mm (1½") diameter with 12 mm (½") high lettering and brass jack chain for fastening to the valve.
- c. Number valves in each system consecutively.
- d. Provide a valve tag directory showing valve number, location, service, make/model/size, with/without hand wheel, type of control and normal position.
- e. The valve tag directory to be mounted in a metal frame and protected with acrylic sheet.

5. Duct Identification

- a. All ductwork to be identified with black stenciled paint. Stenciling shall be in capitalized block lettering, 65 mm (2½") high.
- b. Duct identification to be:

Duct Service	Legend
Supply air, Air handing unit # []	S/A – AH-[]
Return air, Air handing unit # []	R/A – AH-[]
Outside air intake, Air handing unit # []	O/A – AH-[]
Exhaust or relief air, Air handing unit # []	E/A – AH-[]
Exhaust air, Exhaust Fan # []	E/A – EF-[]
Fume Hood air, Fume Hood Fan # []	FH/A-FHF-[]

6. Piping Identification

- a. All exposed piping shall be identified.
- b. Provide vinyl pipe markers that are visibly accessible for maintenance and operations. Include direction of low arrows.
- c. Colour code marker background with clearly printed legend to identify the contents of the pipe. Colours, lettering size and legend to conform to ANSI A13.1 latest edition.
- d. Identify potable water lines to distinguish them from non-potable water lines. Non-potable water line identification to meet requirements of CSA B128.1-06/B128.2-06.
- e. Natural gas and propane gas piping identification system to comply with CAN/CGAB149.1.
- f. Fire sprinkler system component signs to comply with NFPA 13.
- g. Standpipe and hose system component signs to comply with NFPA 14
- h. Pipe identification to be:



Contents	Legend
High temperature hot water supply	HTHWS
Hot water heating supply	HWS
Hot water heating return	HWR
Chilled water supply	CHWS
Chilled water return	CHWR
Glycol supply	GLYS
Glycol return	GLYR
Domestic cold water	DCW
Domestic hot water	DHW
Domestic hot water return	DHWR
Tempered water	TW
Non-potable water	NON-POTABLE WATER
Storm water	STORM
Sanitary	SAN.
Acid waste	ACID
Plumbing vent	SAN. VENT
Refrigerant suction	RS
Refrigerant liquid	RL
Natural gas	NATURAL GAS
Fire protection	FIRE PROT. WATER
Sprinklers	SPRINKLERS
Steam – low pressure	LPS (-- kPa)

7. Above Ceiling Equipment Markers

- a. Provide markers in T-bar and drywall type ceilings to identify locations of all dampers, valves and equipment located above the ceilings.
- b. Locate markers on T-bar closed to equipment.
- c. Apply self-adhesive plastic dots, 15 mm (3/4") diameter, colour coded, to T-bar ceiling or access door.
- d. Colour code as follows:
 - i. Yellow – HVAC equipment
 - ii. Red – Fire dampers / smoke dampers
 - iii. Green – Plumbing Valves
 - iv. Blue – Heating / cooling valves.

8. Building Automation System Identification

- a. Utilize tags and nameplates as described for mechanical equipment and valves for automation system components.
- b. Use BAS mnemonics specified in BAS specification sections on tags and nameplates to



identify BAS physical points and equipment.

c. Identify the following BAS components with laminated plastic nameplates:

- i. Remote control unit (RCU) panels.
- ii. Subpanels.
- iii. Associated equipment panels.
- iv. Panel mounted valves; identify function of each valve.

d. Building automation conduit and conductors to be banded orange.

9. Equipment Bases / Housekeeping Pads

a. Paint equipment bases / housekeeping pads grey with 100 mm (4") yellow and black angled bands around edges.

5.16.26 Operation and Maintenance Manuals

1. General

- a. Provide Owner with two copies of Operation and Maintenance Manuals.
- b. Manuals to be submitted in 215x275 mm (8.5" x 11") expanding post binders with durable green-colour cloth covers connected to spine with piano hinges. Binder cover to be hot stamped in gold lettering front and spine. Title of project to be as per title on drawing cover sheet.
- c. In addition to hard copies, an electronic version of the Operation and Maintenance manuals are to be provided in pdf on a USB flash memory stick .
- d. The divider tabs shall be laminate mylar plastic and coloured according to section. Each tab to include tab number and title printed in the tab. The colouring is as follows:
 - i. Mechanical Systems – Orange
 - ii. Certification – Green
- e. Tab 1.0 – Mechanical Systems: Title page with clear plastic protection cover.
 - i. Tab 1.1 – Index: Provide complete index. Include this tab at the beginning of each binder when multiple binders are used.
 - ii. Tab 1.2 – Directory: Provide directory listing names, addresses, and telephone numbers of all Consultants, Contractors, Subcontractors, and all equipment suppliers.
 - iii. Tab 1.3 – List of Mechanical Drawings.
 - iv. Tab 1.4 – Description of Systems: Provide complete description of each system (site services, plumbing, heating cooling, controls, etc.). Include detailed system description and components comprising that system, explanation of how each component interfaces with others to complete the system, location of each thermostat, controller or operating set point. Include a system schematic showing all components comprising



- the central system.
- v. Tab 1.5 – Identification: Provide schedules listing all mechanical equipment with equipment identification tags and equipment description. Provide listing of all valve tags including tag, service and normal position. Provide schedule of all pipe and duct identification colour codes and labels.
- Tab 1.6 – Operation Division: Provide complete and detailed sequence of each major component. Include how to energize, exact location of switches and controls, how the component interfaces with other components, operation and controls, including the operational sequence, operational characteristic changes for summer or winter operation and how to accomplish the changeover, complete with trouble shooting sequence when set-points cannot be maintained and safeguards to check if equipment goes off-line. In addition, list conditions to be fulfilled before attempting equipment start-up, i.e., valve positions, proper glycol mixture concentration, fluid in piping, filters/strainers in place, etc.
- vi. Tab 1.7 – Maintenance and Lubrication Division: Provide detailed preventative maintenance and lubrication schedule for each of the major components to include daily, weekly, monthly, semi-annually, and annually and when-required checks and tasks. Explain how to proceed with each task required for each piece of typical equipment such as bearings, drives, motors, and filters. Compile this information for each typical piece of equipment separate from the shop drawing section.
- vii. Tab 1.8 – Guarantees: Include in this section all written guarantees and performance certificates for work including extended manufacturer warranties.
- f. Tab 2.0 – Certification
- i. Tab 2.1 – Permits and Tests: Include copies of all permits and test reports, including:
- Piped system pressure tests
 - Duct system leakage tests
 - Piped system cleaning and chemical treatment reports
 - Duct system cleaning reports
 - Inspection reports by authorities having jurisdiction
 - Special systems certification reports
- ii. Tab 2.2 – Air Balance: Include complete air balance report.
- iii. Tab 2.3 – Water Balance: Include complete water balance reports.
- iv. Tab 2.4 – Underwriter Transmittal / Letter: Include a letter stating that the Owner's Underwriter has been provided with the Fire Protection Drawings.
- g. Tab 3.0 – Shop Drawings and Maintenance Data
- i. Include shop drawings and maintenance bulletins of all equipment including controls.
- ii. Separate each equipment type under separate indexed tab.



- iii. Include manufacturer's detailed maintenance bulletins and part list with each piece of major equipment.

Appendix A: Approved Alternate List

REFERENCE	ITEM	ACCEPTABLE MANUFACTURERS
General Mechanical Provisions	Electric Motors	Refer to Refer to section 1.2.6 in the electrical standards
	Air and Water Balancing	Tabtek, Hydro Air, BigSky, Systematic.
Pipe & Pipe Fittings		
	Valves (General Service): Gate, Globe, Swing Check	Victaulic, Crane, Grinnell, Red & White, Lukenheimer, Milwaukee, Kitz
	Ball Valves with stem packing gland nut	Victaulic, Apollo, Crane, Red & White, Grinnell, Watts, Lukenheimer, Milwaukee, Kitz
	Check Valves	Victaulic Crane, Grinnell, Val-Matic, Duo-Check, Nibco, Jenkins, Watts, Milwaukee, Kitz
	Spring Loaded Check Valves	Victaulic, M&G Mission, Mueller, Centre Line, Check Rite, Grinnell, Nibco, Watts; Milwaukee
	Plug Cocks	DeZurik, Grinnell, Keystone, Milliken, Holmstead
	Strainers	Victaulic, Watts, Bell & Gosset, Kitz
	Butterfly Valves	Crane, Keystone, Grinnell, Lunkenheimer, Nobco, Bray, Milwaukee, Kitz
	Pressure Reducing Valves	Bell & Gossett, Armstrong, Taco
	Relief Valves	Spirax Sarco, Lunkenheimer
	Combination Balancing Valves & Flow Meters	Victaulic, Gerand, Presso, Armstrong
	Flow Meters	Gerand, Preso, Armstrong

REFERENCE	ITEM	ACCEPTABLE MANUFACTURERS
	Pressure Gauges	Ashcroft Inc, Marsh-Bellofram, HO Trerice Co., Weksler Gauges, WIKA Instrument Co., Winters
	Bases, Hangers & Supports	Hilti, Grinnell, Unistrut, Myatt, Hunt, CCTF, Crane, Sarco
	Pipe	Crane, Grinnell, Jenkins, Victaulic, Mech-Line, Ladish, Taylor Forge
	Acid Pipe	Labline or Equal
	Grouved Pipe & Fittings	Victaulic, Gruv-Lok
	Plastic Pipe & Fittings	Building Products Orion, Emoc, Domm-A, Scepter, Canplus
	Fancoil Hoses Kits	Victaulic, Hays
Expansion Compensation	Flexible Pipe Connection	Mason, Proco, Senior Flexonics, Lo-Rez, Steamflo
	Expansion Joints and Compensators	Mason, Proco, Senior Flexonics
Plastic Pipe and Fittings		Building Products Orion, Emoc, Domm-X, Scepter
Identification	Pre-printed Pipe Markings	Bradey, SMS
Piping Equipment:		
Pumps	In-Line Centrifugal	Grundfos, Taco, Armstrong, Bell & Gosset
	Vertical In-Line Pumps and Base Mounted Pumps	Armstrong, Aurora, Taco, Bell & Gosset
	Submersible Pumps (Double arrangement)	Bell & Gosset, Myers, Hydromatic
	Positive Displacement Pumps	
	Vacuum Pumps (Rotary Vane)	Power
Air Compressors	Air Compressor	Ingersoll-Rand, DV Systems
	Air Compressor (40 HP or greater) – Rotary Screw	Ingersoll-Rand, DV Systems
Tanks	Expansion Tanks	Taco, Clemmer, Expanflex, Hamlet and Garneau, Armtrol
	Above Ground Fuel Storage Tanks	Clemmer
Vibration Isolation	Vibration Isolation	Korfund, Mason, Vibron, Vibro-Acoustics, Lo-Rez, Amber-Booth

REFERENCE	ITEM	ACCEPTABLE MANUFACTURERS
Hydronic Specialties & Accessories		Victaulic, Bell & Gossett, Taco, S.A. Armstrong, Spirax Sarco, Watts
Dirt and air separation		Spirotherm
Insulation:		
Pipe & Equipment Insulation		Johns Manville, Fiberglas, Manson, Knauff
Silencers	Silencers	Vibro-Acoustic, Vibron, Korfund
Duct Insulation	Acoustical Insulation	Johns Manville, Fiberglas, Manson, Knauff, 3M
	Ductwork Insulation – Fiber Glass	Johns Manville, Fiberglas, Manson, Knauff, 3M
	Ductwork Insulation – Natural Cotton Fiber	Bonded Logic Ultra Touch
Fire Protection Systems:		
Sprinkler Equipment	Sprinkler Heads	Central, Reliable, Tyco, Viking
	Fire Pumps	Darling, Aurora, Peerless, Leitch, Armstrong
Hand Held Fire Extinguishers	Hand Held Fire Extinguishers	NFE, Pyro-Chem/Flag Fire
Heating Equipment:		
Gas Fired Heaters	Unit Heaters	Reznor, Lennox
	Infrared Heaters	Roberts Gordon, Schwank
Steam Specialties		Spirax Sarco, Armstrong
Low Pressure Steam Packaged Boilers	Low Pressure Steam Packaged Boilers	Cleaver Brooks, Fulton
Steam Traps	Select type based on application	Dominik, Spirax Sarco
High Pressure Steam Packaged Boilers	High Pressure Steam Packaged Boilers	Cleaver Brooks, Fulton
Hot Water Boilers	Hot Water Boilers	Boderus, Cleaver Brooks, AO Smith, Weil McLean, Camus, Miura, Lochinvar, Fulton
Domestic Hot Water Heaters	Tank Type Gas Fired	Bradford, AO Smith, PVI
	Instantaneous Gas Fired	Takagi, Rinai, Weil McLean, PVI
	Indirect (Double Wall)	Amtrol, HTP, PVI
Pipe Cleaning & Water Treatment	Chemical Treatment Agencies	Specified Technical Sales, Betz Chemicals
Cooling Equipment:		
Chillers		Carrier, Daikin Smardt, York, Trane



Cooling Towers		Baltimore Air Coil, Evapco
Heat Transfer Equipment:		
Heat Exchangers		Armstrong, Bell & Gosset, Alpha Laval, Taco

REFERENCE	ITEM	ACCEPTABLE MANUFACTURERS
Terminal Heat Transfer Units	Baseboard Radiation	Rosemex, Engineered Air, Sigma, Runtal
	Cabinet & Unit Heaters, Convectors	Rosemex, Engineered Air, Sigma, Trane
	Radiant Ceiling Panels	Engineered Air, TWA
Radiant In-Floor Heating	Radiant In-Floor Heating	Wirsbo, Heatlink, Ipex
Coils	Heating, Cooling, Glycol	Aerofin, HeatCraft, Trane, Engineered Air, Daikin
HTHW Control Valve	Pneumatic Control	Fisher, Masoneilan Camflex
Air Distribution Equipment:		
Air Handling Units	Air Handling Unit	Engineered Air, Haakon, Scott Springfield, Ventrol (Huntair), EH Price, Southampton Trane, ICE
	Fans	Greenheck, Twin City, Northern Blower, Chicago Blower, Huntair
	Humidifiers	Dri-Steem, Spirax Sarco, Armstrong, Pure, Condaire, Neptonic
	Heat Recovery Wheels	Semco, S.G.America
	Filters	AAF, Airguard, Cambridge, Farr, Flanders, Viledon
	Test ports on doors	Durodyne or Equal
	Fan Arrays	Huntair, Twin City, Greenheck
	Silencer	Price
Air Conditioning Units – Ductless Splits	Air Conditioning Units – Ductless Splits	Mitsubishi, Carrier, Friederich, Liebert, Samsung, Climateworx
Fan Coil Units	Fan Coil Units	Daikin, Engineered Air, Carrier, Trane
Heat Pumps		Daikin, Trane, Climatemaster, Water Furnace
Gas Fired Make Up Air Units		Engineered Air, ICE, Trane
Fans	Centrifugal Fans	Greenheck, Acme, Chicago, Twin City, Northern Blower
	Roof Mounted Fans	Greenheck, Acme, Loren Cook, Penn
	Axial Fans	Northern Flower, Woods, Joy, Greenheck
	Range Hoods	Broan, Nutone



VAV & CV Boxes		Price, Nailor Industries, Titus, Phoenix
Air Outlets	Air Outlets	Price, Nailor Industries, Titus
	Louvres	Price, Westvent, Ruskin,
	Roof Intakes Exhausts	Greenheck, Acme, Penn, Cook, Jenn-Air

REFERENCE	ITEM	ACCEPTABLE MANUFACTURERS
Duct Accessories	Fire & Smoke Dampers	Ruskin, Nailor, Greenheck, Price
	Back Draft Dampers	Ruskin, Tamco, T.A. Morrison, Westvent, Greenheck, Price
	Control Dampers	Ruskin, Tamco, Nailor, Alumavent (ventex)
	Fume extraction arms	Nederman, plymovent
Controls	Contractors & Automatic Control Systems	Siemens
	Lab Gas Detection	Volcano 301 gas detector or approved equal
Metering Devices	Flow meter	Endress Hauser or Veris
	Airflow Sensors/Stations	Ebtron, Paragon, Air Monitor, or equivalent

Appendix B: List of Acceptable Plumbing Fixtures

1. Table B-1 lists all acceptable plumbing fixture manufacturers and model numbers for the University of Calgary.
2. Table B-2 lists all acceptable plumbing fixture trim manufacturers and model numbers for the University of Calgary.
3. Any deviation from list, submit cut sheets of fixtures and trim to be submitted to Campus Engineering for review and approval during the design phase.

Table B-1: List of Acceptable Plumbing Fixture Manufacturers and Model Numbers

Fixture Type	Description	Manufacturer	Model
Water Closet Flush Valve 4.8L per Flush (Wall mounted preferred)	Wall Mounted	American Standard	AFWALL 3351 128
		Kohler	K-4325
		Crane	
	Wall Mounted (Barrier Free)	American Standard	AFWALL 3351 128
		Kohler	K-4325
		Crane	
	Floor Mounted	American Standard	MADERA 3451 128
		Kohler	K-4406
		Crane	
	Floor Mounted (Barrier Free)	American Standard	MADERA 3461 128
		Kohler	K-4405
		Crane	
Water Closet Tank Type	Dual Flush (6L/3L per flush)	American Standard	FloWise 2476 216
		Caroma	CARAVELLE 270
		Crane	

Fixture Type	Description	Manufacturer	Model
	Dual Flush Barrier Free (6L/3L per flush)	American Standard	FloWise 2476 216
		Caroma	CARAVELLE 270
		Crane	
	Dual Flush Residential (6L/3L per flush)	American Standard	FloWise 2476 216
		Caroma	CARAVELLE 270
		Crane	
Urinal (1/8 gpf)	Ultra Low Flow 1/8 gallon per flush	Zurn	Z5799
		Kohler	K-4904-ET
		American Standard	6590.125
	Countertop for private offices only	American Standard	To suit project
		Crane	To suit project
		Kohler	To suit project

Lavatory	Countertop (Barrier Free) for private offices only	American Standard	To suit project
		Crane	To suit project
		Kohler	To suit project
	Undermount Stainless Steel - for public washrooms	Kindred / Franke	To suit project
		Elkay	To suit project
	Undermount Stainless Steel (Barrier free) - for public washrooms	Kindred / Franke	To suit project
		Elkay	To suit project
	Pedestal Type	American Standard	To suit project
		Crane	To suit project
		Kohler	To suit project
Wall Mounted	American Standard	To suit project	
	Crane	To suit project	
	Kohler	To suit project	
Service Sink	Service Sink 36" x 24"	Fiat	MSB-3624
		Stern Williams	MTB-3624
		Zurn	Z1996-36
	Service Sink 24" x 24"	Fiat	MSB-2424
		Stern Williams	MTB-2424
		Zurn	Z1996-24
Lab Sink	Stainless Steel	Kindred / Franke	To suit project
		Elkay	To suit project
	Cup Sink	Kindred / Franke	To suit project
		Elkay	To suit project
		IPEX	To suit project
	Deep Sinks	Steel Craft	To suit project
		Elkay	To suit project
Kitchen Sink	Stainless Steel	Kindred / Franke	To suit project
		Elkay	To suit project
Hand Wash Lab Sink	Barrier free, SS single bowl sink.	Novanni	4207ADE10
		Elkay	WLC1923OSDC

Fixture Type	Description	Manufacturer	Model
Shower Stall	Residential Shower	Custom – by Architect	To suit project
	Single Stall Minimum 36" x 36"	Fiat	To suit project
		Hytec	To suit project
Bathtub	Self-Contained Tub/Shower Enclosure - Residential	Fiat	To suit project
		Hytec	To suit project
Drinking Fountain with Bottle Filler Use refrigerated only when approved by Campus Engineering	Wall Mounted - Refrigerated	Hawas	HWUACP8SS
		Elkay	EZO8
		Oasis	
	Wall Mounted - Non-Refrigerated	Haws	1109.14
		Elkay	
Bottle Filling Station	Semi-Recessed	Haws	Hydration Station 2000
		Elkay	EZH2O

Emergency Fixtures	Refer to Lab standards sections 6.3.15		
Acid / Dilution Trap	Main Receiver	IPEX	Size to building load
	Individual Fixture Receiver	IPEX	DB Series
Grease Trap		Watts	Size to building load
		Ashland Polytrap	Size to building load
Sediment Trap	Custom-made by sheet metal shop	Stainless Steel: Custom made by sheet metal shop	
		IPEX	

Table B-2: List of Acceptable Plumbing Fixture Trim Manufacturers and Model Numbers

Trim Description	Manufacturer	Model
Water Closet Flush Valve Auto Flush – 4.8 lpf Public High Use Areas (Hard Wired)	Sloan	Royal Optima 111-1.28 ES-S
	Moen	8311AC12
	Delta Commercial	
Water Closet Flush Valve Manual Flush – 4.8 lpf Public High Use Areas	Sloan	Royal 111.28
	Moen	
	Delta Commercial	
Urinal Auto Flush Ultra Low Flow (1/8 gpf) (Hard Wired)	Sloan	Royal Optima 186-0.13 ES-S
	Moen	8315 AC05
Lavatory electronic Faucet – High Use =< 0.5 gpm (this our preferred faucet, please)	Moen (push type)	8894

Trim Description	Manufacturer	Model
contact Campus Engineering for alternates)		
Lab Sink Faucet	Delta Commercial	User specified
	T & S	User specified
	Moen	User specified
Kitchen Sink Faucet	Delta Commercial	User specified
	T & S	User specified
	Moen	User specified
Service Sink Trim and	Fiat	830-AA c/w 1.5m of 15mm plain end reinforced rubber hose, hose clamp, and mop hanger
	Delta Commercial	28T9



Accessories	Zurn	Z1996-SF-MH-HH c/w 1.5m of 15mm plain end reinforced rubber hose, hose clamp, and mop hanger
Shower – Non Residential – Head & Valve 1.5 gal shower head	Delta Commercial	
	Moen	
	Symmons	
Shower – Barrier Free – Non Residential Head & Valve 1.5 gal shower head	Delta Commercial	
	Moen	
	Symmons	
Shower Head – Residential – Head & Valve 1.5 gal shower head	Delta Commercial	
	Moen	
	Symmons	
Shower Head – Non Residential 1.5 gal shower head	Bricor	
	Symmons	
Shower Head – Residential 1.5 gal shower head	Bricor	
	Moen	
Shower Mixing Valve – Non Residential	Leonard	
	Moen	
	Powers	
Shower Mixing Valve - Residential	Leonard	
	Moen	
	Powers	
Drains – Floor / Roof / Misc.	Watts	To suit structure
	Zurn	To suit structure
Backflow Preventors	Watts	-
	Zurn	-
Hose Bibb - Moderate Climate	Watts	HY-430
	Zurn	-
Hose Bibb – Non Freeze	Watts	HY-420
	Zurn	-

Trim Description	Manufacturer	Model
Laundry Valve	Watts	IntelliFlow A2C-M1

Appendix C: Acceptable Pipe and Fitting Materials List

1. Table C-1 lists all pipe and fitting materials for the University of Calgary
2. Domestic water, drainage, and vent piping to comply with latest plumbing code.

Table C-1: Pipe and Fitting Materials List

Service	Size	Material	Fittings	Joints
Plumbing and Services				
Sanitary and vent Piping above grade	65 & under	DWV copper		
	75 & larger	ASTM B306 Cast iron, CSA B70		
Sanitary and vent Piping below grade (inside building)				
	75 & larger	Cast Iron		
Sanitary and vent Piping below grade (outside building)	65 & under	ABS		
	75 & larger	Cast Iron		
Storm above grade	65 & under	DWV copper		
	75 & larger	Cast Iron		
Storm below grade (inside building)	65 & under	ABS		
	75 & larger	Cast Iron		
Storm below grade (outside building)	65 & under	ABS		
	75 & larger	Cast Iron		
DCW, DHW, Tempered, Non-potable	50 & under	Type L Copper		
	65 & larger	Type L Copper		
DHWR	All sizes	Type L Copper		
DCW below grade	75 & under	Type L Copper		No Joints
	100 & larger	- 316L Stainless Steel. - BLK sched 40 epoxy coated Bituminous. - Asphalt cast iron Pipe (with Denso tape).		
Natural Gas				
Above grade accessible joints	50 & under	Sch. 40 BI		
	65 & larger	Sch. 40 BI		
Above grade inaccessible joints	All sizes	Sch. 40 BI		
Fire Protection				
	50 & under	Sch. 40 BI		
	65 & larger	Sch. 20 BI		
Heating				
Hot water / glycol	50 & under	Sch. 40 BI		
	65 – 250	Sch. 40 BI		
High temperature hot water	All sizes	Sch. 40 BI		



Service	Size	Material	Fittings	Joints
Steam to 103.4 kPa	50 & under	Sch. 40 BI		
	65 – 250	Sch. 40 BI		
	300 & larger	Sch. 40 BI		
Low Pressure & Pumped Condensate	50 & under	Sch. 80 BI		
	65 & larger	Sch. 80 BI		
Cooling				
Chilled water	50 & under	Sch. 40 BI		
	65 & larger	Sch. 40 BI		



Appendix D: Spare parts list

Service	Part	Quantity
Chemical Treatment Supplies	Bypass filter – 50 micron string wound filter media for startup and 20 micron for system polishing on hydronic and glycol systems	20 for each size and type per system
	Hydronic system fluid	Amount equal to 50% of initial fill charge for each system.
	Glycol system fluid	Amount equal to 40% of initial fill charge
Fire Dampers	Fusible links (74°C)	5 of each type
Pump	Seals	One for each pump
Air Handling	Air filters	One for each system
Fan coils	Air filters	One for each unit
Refrigeration (lubricating oil)	Air cooled refrigerant condenser	Amount equal to 100% of initial charge for each system.
	Air cooled condensing units	Amount equal to 100% of initial charge for each system.
Valves	washers	10 for each valve size and type
	seals	10 for each valve size and type
Belt Driven Equipment	Belts	One set of belts for each drive type and size
Energy Management and Control System (EMCS) work.	TEC for each size of terminal unit	One
	Sensor for each system	One
	Actuator for each damper set	One
	Valve actuator for each type	One
	TEC for each size of terminal unit	One

Revision History

Revision Date	Version	Description
Oct 2022	1.1	Baseline version
August 10, 2023	1.0	Added Revision History table to end of document and reset to Version 1.0.
January 15, 2024	2.0	Various minor updates to 5.16.28 Controls
May 17, 2024	3.0	Removed date references on standards. Update to figures in Sections 5.16.6.4 and 5.16.4.4. Added clarification to PEX pipe in Section 5.16.17.2. Added Spirotherm as approved equipment for Air & Dirt Separators, added PVI as approved equipment for DHW Heaters and HW Boilers, added Neptronic as approved equipment for AHU Humidifiers. Format changes.
December 2025	4.0	Removed Control section to new standard 5.23 Building Automation System. Updates section numbering and formatting.